

SUMMIT ICE SHACK

8'-4" x 12'-0"

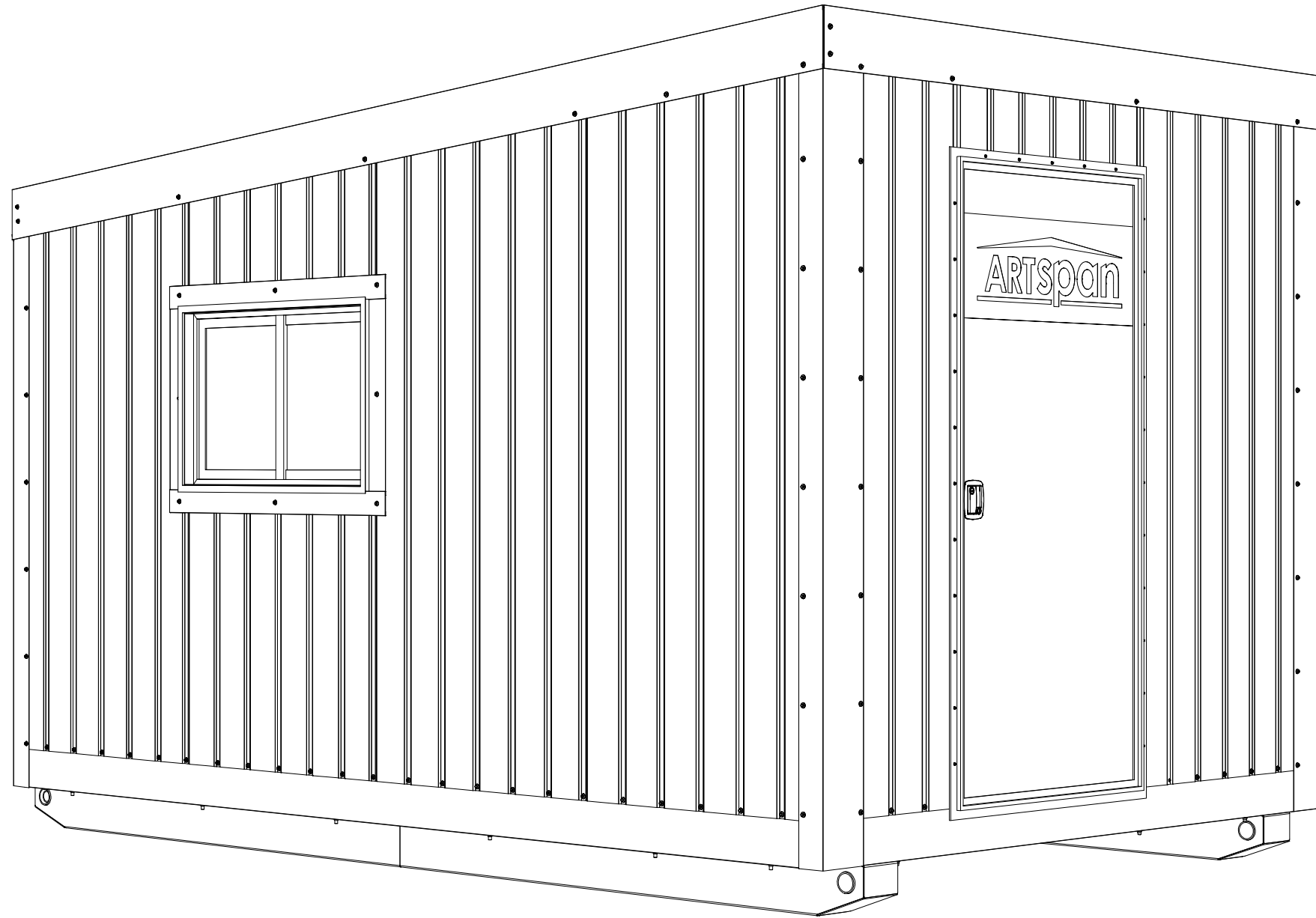

IMPORTANT: INSPECT ALL PANELS AND COMPONENTS FOR DAMAGE OR DEFECTS PRIOR TO ASSEMBLY

TOOL LIST

(NOT SUPPLIED)

- 3/8" HEX DRIVER
- #2 ROBERTSON BIT
- DRILL/IMPACT
- UTILITY KNIFE
- CAULKING GUN
- LEVEL
- SQUARE
- MEASURING TAPE
- MARKER
- TIN SNIPS
- SPRAY FOAM
- NON-SLIP FLOOR FINISH (IF DESIRED)
- GLOVES
- SAFETY GLASSES
- EAR PLUGS

SAFETY

- USE OF HIGH QUALITY GLOVES, EAR PLUGS & SAFETY GLASSES ARE REQUIRED FOR ASSEMBLY OF THIS PRODUCT. EDGES OF MATERIALS MAY BE EXTREMELY SHARP. FASTENING INTO METAL CAN PRODUCE HIGH DECIBELS, EAR PLUGS MUST BE WORN.
- FLOOR CAN BE SLIPPERY. ADDING A NON-SLIP FINISH TO THE TOP OF THE FLOOR PANELS IS RECOMMENDED.
- CONSULT RECOMMENDED VENTILATION GUIDELINES FROM HEAT APPLIANCE MANUFACTURER PRIOR TO USE TO ENSURE ICE SHACK IS PROPERLY VENTILATED.
- DO NOT EXCEED SPEEDS OF 10KM/HR WHILE TOWING ICE SHACK, ENSURE SHACK IS BROKEN FREE FROM ICE/SNOW PRIOR TO TOWING.
- CONSULT LOCAL REGULATIONS TO DETERMINE REFLECTOR AND SAFETY REQUIREMENTS PRIOR TO USE.

ADDITIONAL NOTES

- ENSURE SIKAFLEX 1A/SILICONE ARE AT ROOM TEMPERATURE PRIOR TO USE
- SIKAFLEX 1A/SILICONE QUANTITIES ARE BASED ON STANDARD FACTORY USAGE

TOOL LIST

(SUPPLIED)

- PANEL CLAMP
- 20oz CAULKING GUN
- 3/8"x6" DRILL BIT



Artspan Inc. Warranty and Limitation of Liability

Between Artspan Inc. ("Artspan") and The Purchaser, Dealer, Builder or Buyer on the Front Hereof (the "Purchaser")

WARRANTY AND LIMITATION OF LIABILITY

IMPORTANT: INSPECT PANELS PRIOR TO INSTALLATION - DAMAGE OR DEFICIENCIES MUST BE REPORTED PRIOR TO INSTALLATION TO DETERMINE COURSE OF ACTION.

(1) Artspan warrants that its Goods when installed in a normal and proper manner, shall be free from any defect due to materials or workmanship for a period of one (1) year from the date of delivery. Artspan's sole obligation under this warranty is to repair or replace such part or parts that are shown to the satisfaction of Artspan to be defective within the warranty period to an amount not in excess of the amount under this Agreement. The Purchaser shall notify Artspan in writing immediately upon discovery of any defect and Artspan shall have no liability hereunder for any claims, including shortages and field re-work. This warranty does not apply:

- a. to any Product sold by Artspan where said Product is used in areas exposed to corrosive or aggressive conditions including, but not limited to, salt water, acids, alkaloid, ash, cement dust, animal waste or other corrosive chemicals from either inside or outside the structure;
- b. for failures or defects arising out of damage during shipment or during storage on site;
- c. to materials replaced or repaired under this Warranty except to the extent of the remaining term under this Warranty (if any);
- d. to damage resulting from misuse, negligence, accident or improper site preparation by the Purchaser;
- e. to parts and accessories and other components of the Product that are not manufactured by Artspan;
- f. if the Product has been altered or modified by persons other than Artspan;
- g. in the case of coating failures where the failure is the result of damage by the buyer, lack of proper maintenance by the buyer or the buyer's failure to remove road salt and/or other contaminants the Product may have come into contact with;
- h. to loss of time, inconvenience, loss of material, down time or any other consequential damage;
- i. to coating repairs in respect of minor blemishes or rusting that occurs in the ordinary course and is associated with general maintenance of the Product;
- j. to excessive wear on interior coatings of the Product;
- k. to the Product, if used for a purpose which differs from the purpose intended by Artspan;
- l. if the Product has not been erected, operated and installed strictly in accordance with Artspan's manuals and instructions;
- m. to damage caused by acts of God, falling objects, external forces, explosions, fires, riots, civil commotions, and acts of war, excessive radiations, or any other occurrences beyond the Manufacturer's control.
- n. to damage to the panels resulting from edge corrosion or failure of the metal substrate is not covered by this warranty.
- o. to damage to the panels caused directly or indirectly by panel contact with fasteners is not covered by this warranty. The responsibility for selection of suitable long-lasting fasteners rest solely with the Purchaser.
- p. to damage caused by steel shavings or minute particles from sawing sparks that come into contact with the pre-painted finish
- q. to defects or damage to the pre-painted finish of the product, after delivery by Artspan, resulting from handling, shipping, transit, processing, improper storage or installation, or prolonged moisture contact or contact with corrosives and/or similar

(2) Artspan shall not be liable for any incidental loss or damage, however caused, including, without limitation, normal wear and tear. In addition, the warranty expressed hereunder shall be void in the event that an alteration or repair is made to the Goods by any person other than as authorized by Artspan. This warranty does not include expendable components, if any, and any components not manufactured by Artspan.

(3) Artspan makes no express or implied warranties of any nature whatsoever except for such express warranties as set out herein. The warranty provided herein is in lieu of and excludes all other warranties, guarantees or conditions pertaining to the Goods, written or oral, statutory, express or implied, (except the warranty as to title) including any warranty as to the merchantability or fitness for any particular purpose. Artspan expressly disclaims all other representations, conditions or warranties, express or implied, statutory or otherwise and any representations, warranties or conditions that may arise from a course of dealing or usage of trade. The warranty provided herein shall constitute Artspan's sole obligation and liability and the Purchaser's sole remedy for breach of warranty. No other warranty has been made by any employee, agent, or representative of Artspan and any statements contained in any other printed material of Artspan is expressly excluded herefrom. Artspan shall not be responsible for any warranty offered by the Purchaser to any of its customers with respect to the Goods and the Purchaser shall indemnify Artspan with respect to same if any of those customers make a claim against Artspan relating to any such warranty. The warranty of Artspan is not assignable by the Purchaser.

(4) Artspan may at its sole discretion provide an extended warranty on the Goods, including but not limited to Galvalume® or pre-painted panels against perforation or paint failure. Such warranty shall be in writing and shall be signed on behalf of Artspan.

(5) In no event will the total liability of ARTSPAN for any damages incurred by the Purchaser ever exceed the fees actually paid by the Purchaser to ARTSPAN under this Agreement, regardless of the form of action, whether based in contract, tort, warranty, negligence, strict liability, products liability or otherwise.

(6) Oil canning and perceived waviness in the surfaces of insulated steel panels is an inherent part of the light gauge formed metal used for the faces. Surface irregularities may also be more noticeable when the metal face is coated with a highly reflective paint finish or certain colours. Oil canning is not cause for rejection or warranty claim. As an aesthetic issue only, it in no way affects the performance, structural integrity, or the paint associated with Artspan products.

(7) Artspan shall not have any obligation under this Warranty until all accounts for materials, installation and erection of the Product, including all labor and other costs associated with the work performed by Artspan, have been paid for in full by the Purchaser.

(8) The obligation of Artspan under this Warranty shall not arise until Artspan is notified in writing and this Warranty is presented together with a written statement by the buyer specifying the claim or defect. Such notice and written statement to be delivered to Artspan within thirty (30) days of the date the defect was first discovered.

(9) If it is determined by Artspan, in its sole discretion, upon inspection, that a claim for a defective Product is valid, liability for breach of this Warranty and the sole remedy of the Purchaser shall be limited to either repairing or replacing the defective part(s) of the Product. No other remedy (including but not limited to the recovery of assembly or disassembly costs, shipping costs, direct, incidental, special, indirect consequential damages for lost profits, lost sales, injury to person or property or any other loss, whether arising from breach of contract, breach of warranty, tort, including negligence, strict liability or otherwise) shall be available to the Purchaser or any other person or entities whether by direct action, third party claim, or indemnity or otherwise against Artspan and/or its officers, directors, servants and agents.

(10) The obligation of Artspan hereunder extends only to the original buyer to whom the Product was sold. This Warranty is non-transferable and non-assignable without the prior written consent of Artspan.

(11) The Purchaser acknowledges that the Product has been customized for the buyer and the buyer has made its own independent decision to approve the use of the supplied materials in the Product as well as the specific fabrication and construction procedures utilized to complete the Product and has satisfied itself as to the suitability of the Product for its particular application.

(12) Artspan does NOT warranty that any building material or any other material used in the manufacturing process of the Product meets local or municipal ordinances, codes, or other regulations.

(13) The buyer shall inspect material received from Artspan prior to installation so as to mitigate expenses involved in repairing, repainting or replacing defective panels.

(14) Warranty Claim Procedure:

- a. Notify Artspan in writing upon discovery of any defect(s), and in any event, no later than thirty (30) days from the date the defect was first discovered.
- b. Complete the warranty claim statement and submit with a copy of this Warranty to the Artspan for review. To be effective, the buyer shall include in all claims under this Warranty adequate identification of material(s) involved in the claim, including original invoice.
- c. Artspan shall then have a reasonable opportunity to inspect the product before any further action shall be taken.



TYPICAL PANEL CLAMPING

Apply Sikaflex 1A bead as per connection detail. Move panels to be clamped as close to each other as possible. Clamp panels together within the deep flute of the panels (CL1-CL2). Ensure tops of panels are relatively flush (CL2). Small variations are acceptable. Fasten through panel joints with 193204 screw 1" from the top of the panels. Repeat steps for the bottom of the panel ensuring full contact is made.

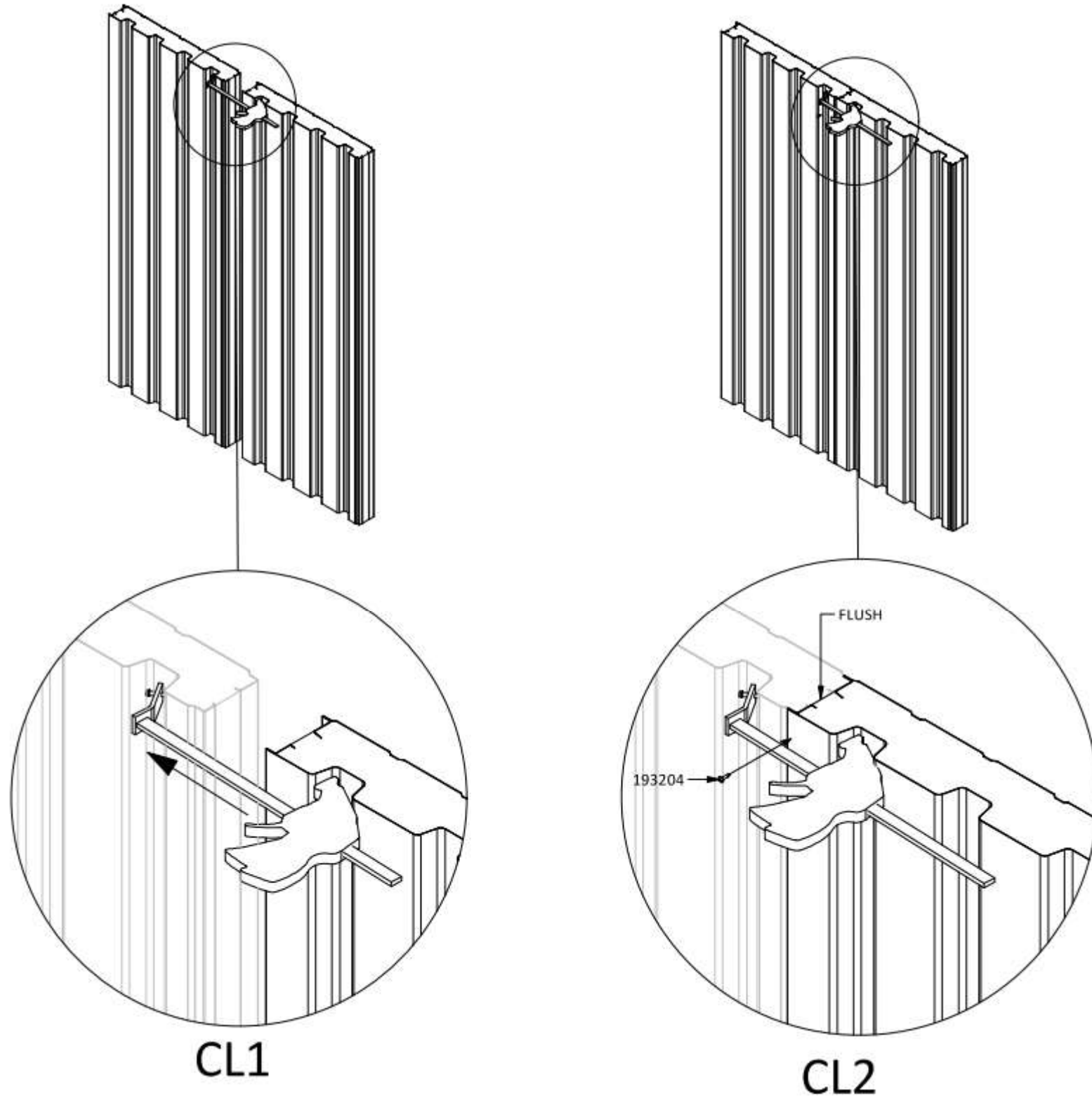

20oz CAULKING GUN LOADING

- Remove nozzle from gun
- Pull back plunger
- Slide unopened Sikaflex 1A into gun
- snip the aluminum collar from the end of the Sikaflex tube
- Reinstall nozzle

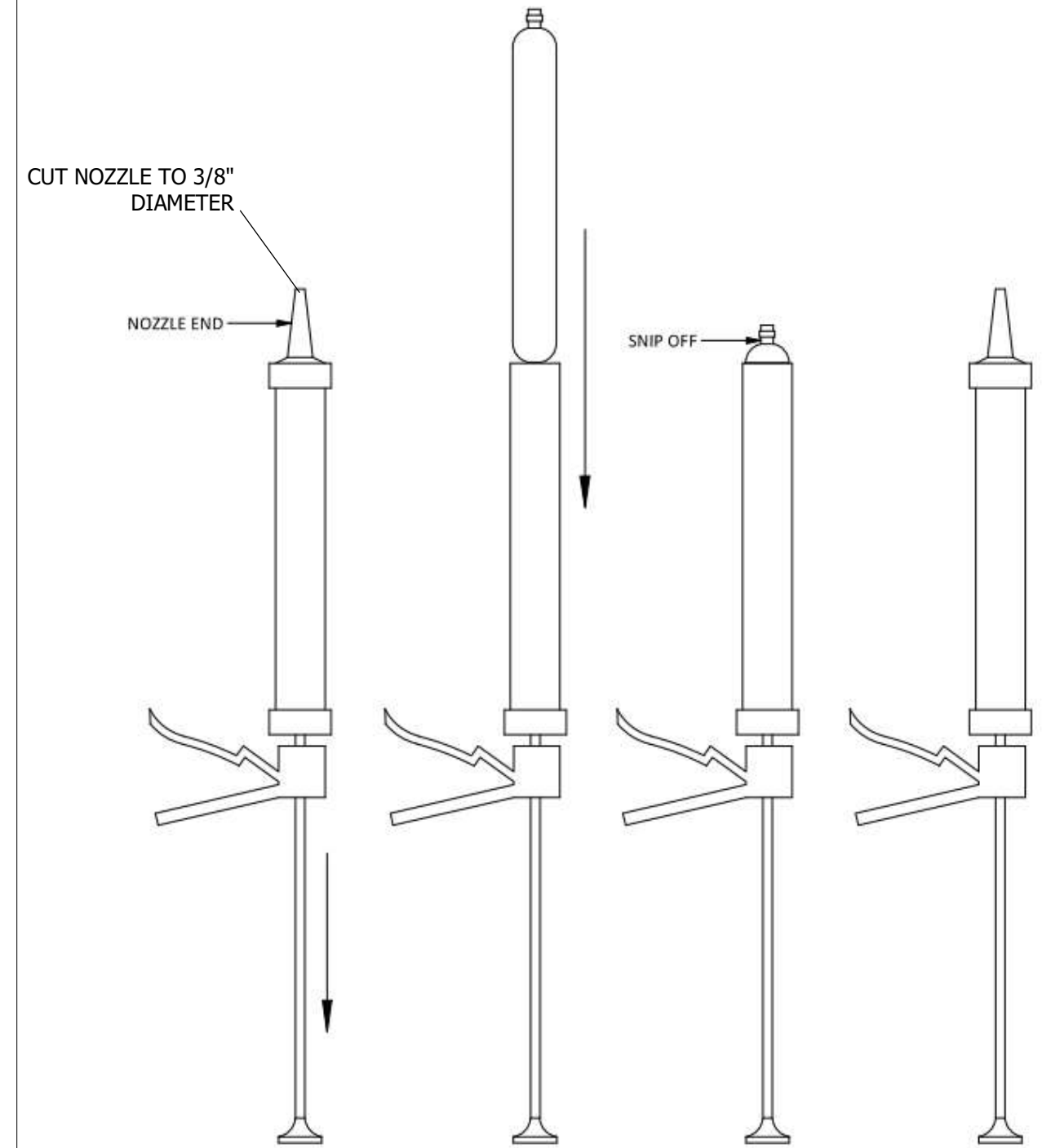

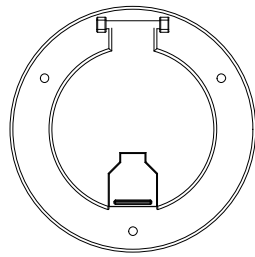

192569(X2)
BLACK 3 1/2"
INLET PORT

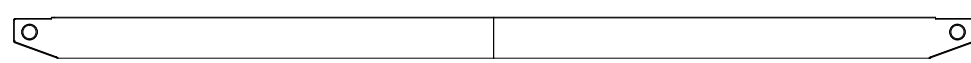

192574(X2)
12' SKI

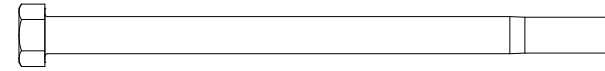

193226(X26)
3/8" X 6" BOLT



193202(X24)
1/4"-14x6"

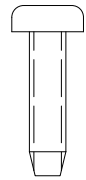

193211 (X120)
#10 X 3/4"
DRILLING SCREW

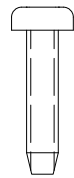

193218(X380)
#8 X 3/4"
POINTED SCREW

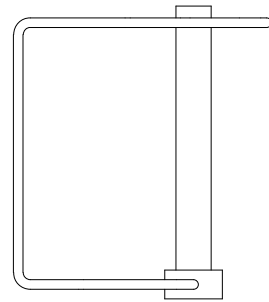

193223(X1)
3/8" SQUARE LYNCH PIN

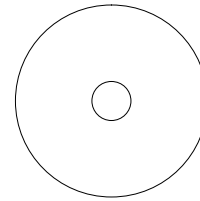

193228(X58)
3/8" FENDER WASHER

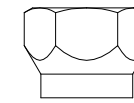

193227(X29)
3/8" LOCK NUT

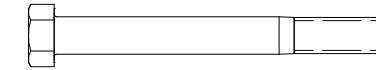

193224(X3)
3/8" x 3 1/2"
BOLT

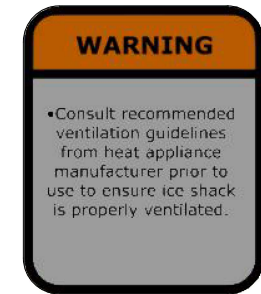

192601(X1)
VENTILATION DECAL

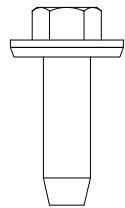

193236(X225)
#12X1 BLACK SCREW

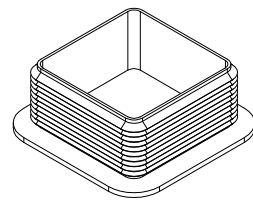

192621(X6)
TUBE PLUG 2x2x0.125

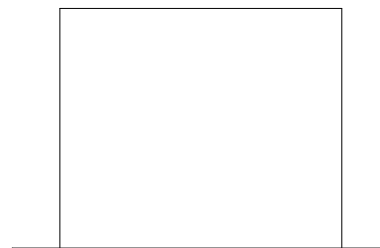

192603(X1)
CHIMNEY 6" SLEEVE

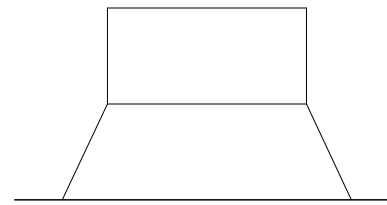

192604(X1)
CHIMNEY ROOF FLASHING

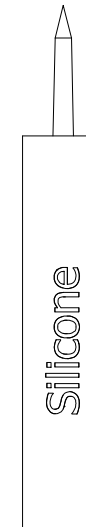

192527(X3)
SILICONE TUBE

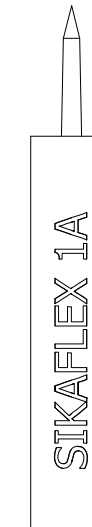

192522(X13)
SIKAFLEX 1A

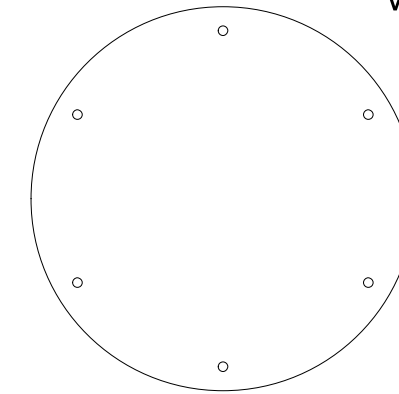

192605(X1)
ROUND CHIMNEY HOLE CAP



192602(X1)
TOWING DECAL FOR
ONE TOW BAR PLATE

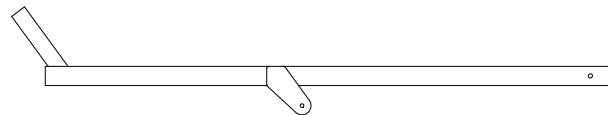

192618(X2)
TOW BAR ARM



192710(X34)
FOAM CLOSURE

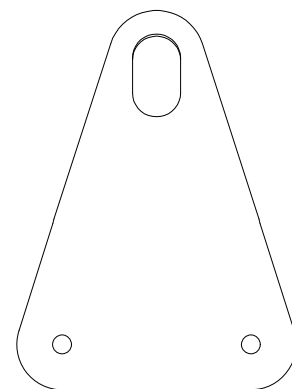

192620(X2)
TOW BAR PLATE

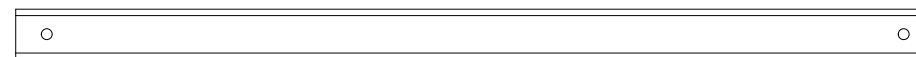

192619(X1)
TOW BAR CROSS TUBE

CROSS SECTIONS

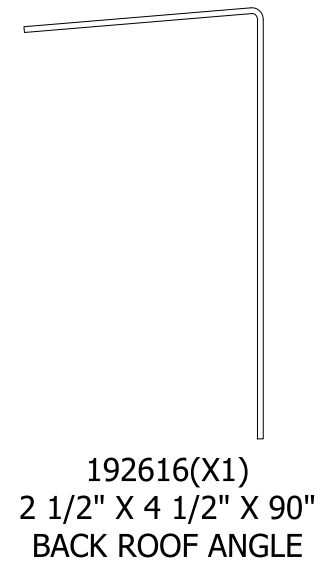

192613(X4)
4 1/2" X 2 1/2" X 72"
ANGLE



192614(X2)
4" X 2 1/2" X 83"
ANGLE



192615(X1)
2 1/2" X 4 1/2" X 90"
FRONT ROOF ANGLE

192592(X3)
3" WINDOW TRIM

192595(X4)
6" X 3/4"
BASE TRIM

192594(X9)
3 1/2" X 7"
ICE SHACK TRIM

192591(X2)
2" X 2 1/2"
INSIDE WINDOW TRIM

192610(X3)
FLOOR CHANNEL 88.5"

192617(X2)
4 1/2" X 2 1/2" X 62.75"
ANGLE

192593(X2)
4 1/2" X 2"
INSIDE DOOR TRIM

193239(X1)
3/8" X 6" DRILL BIT

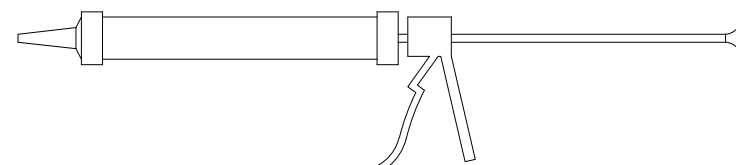
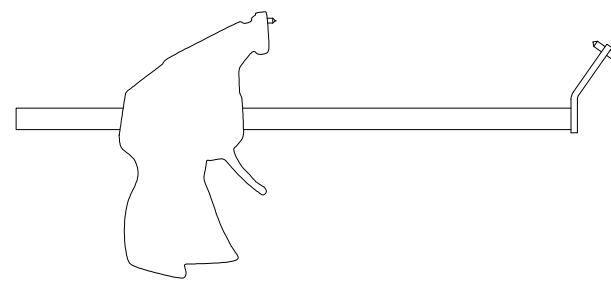
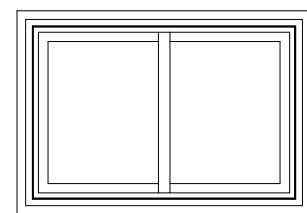
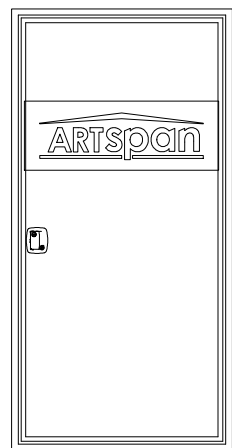

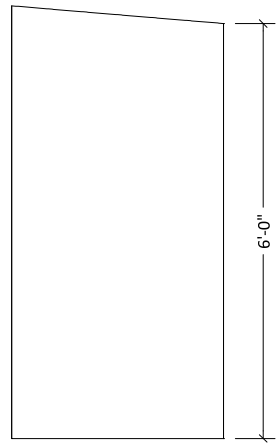

W1(X1)
WALL PANEL

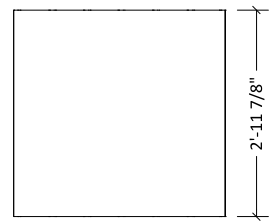

W2(X2)
WALL PANEL



W3(X1)
WALL PANEL

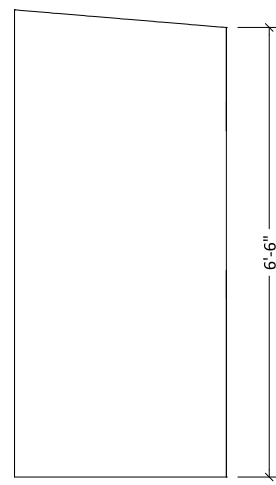

W4(X1)
WALL PANEL

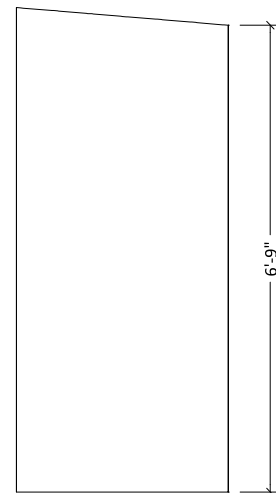

W5(X1)
WALL PANEL

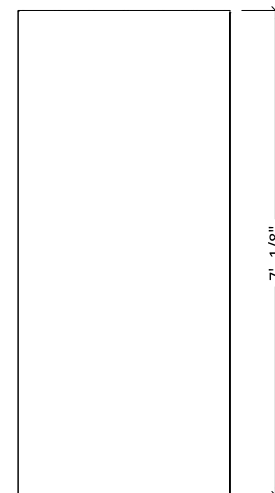

W6(X1)
WALL PANEL

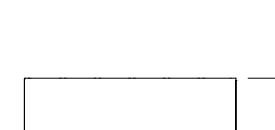

W7(X1)
WALL PANEL

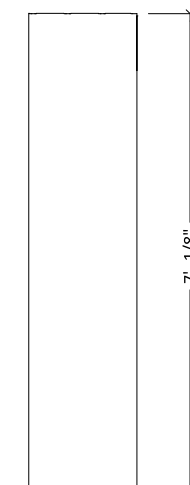

W8(X1)
WALL PANEL

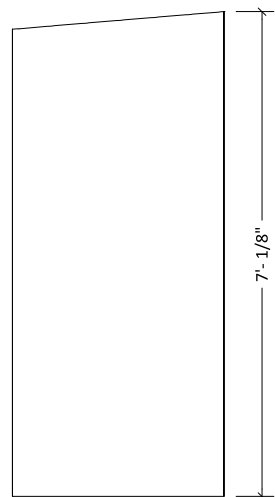

W9(X1)
WALL PANEL

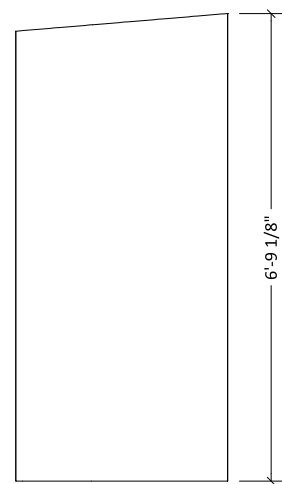

W10(X1)
WALL PANEL



W11(X1)
WALL PANEL

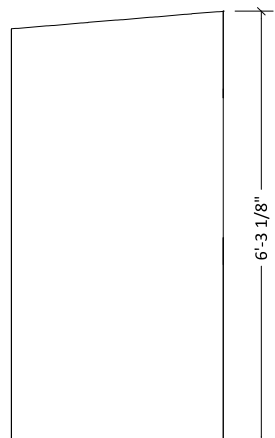

W12(X1)
WALL PANEL

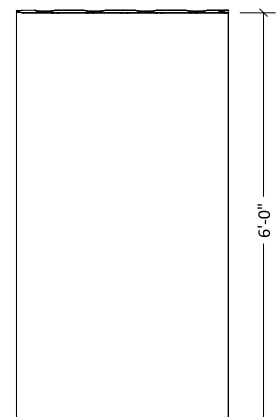

W13(X2)
WALL PANEL

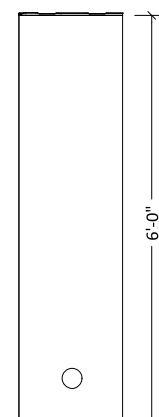

W14(X1)
WALL PANEL

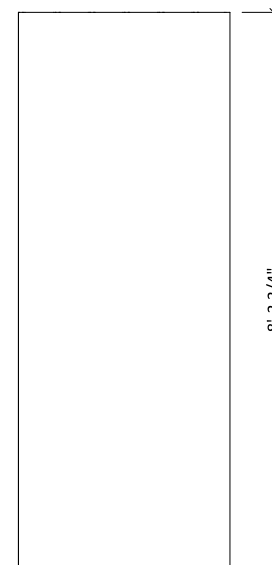

F1(X4)
FLOOR PANEL

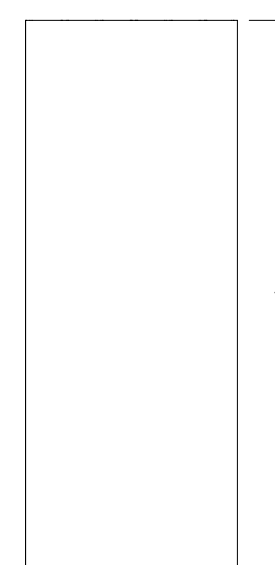

R1(X3)
ROOF PANEL

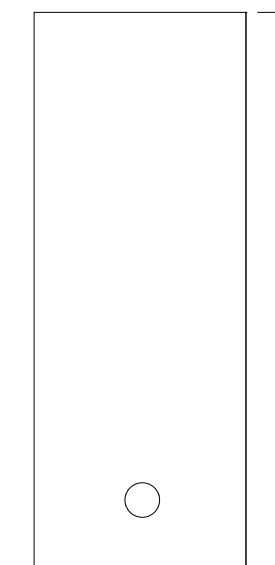

R2(X1)
ROOF PANEL

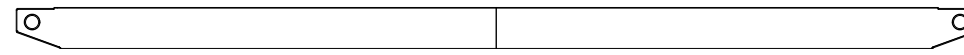
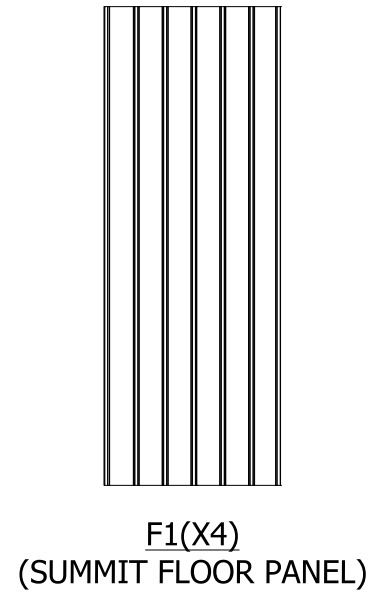

192574(X2)
(12' SKI)



192522
(SIKAFLEX 1A)

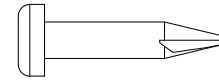

193211(X9)
(#10x3/4 DRILLING SCREW)

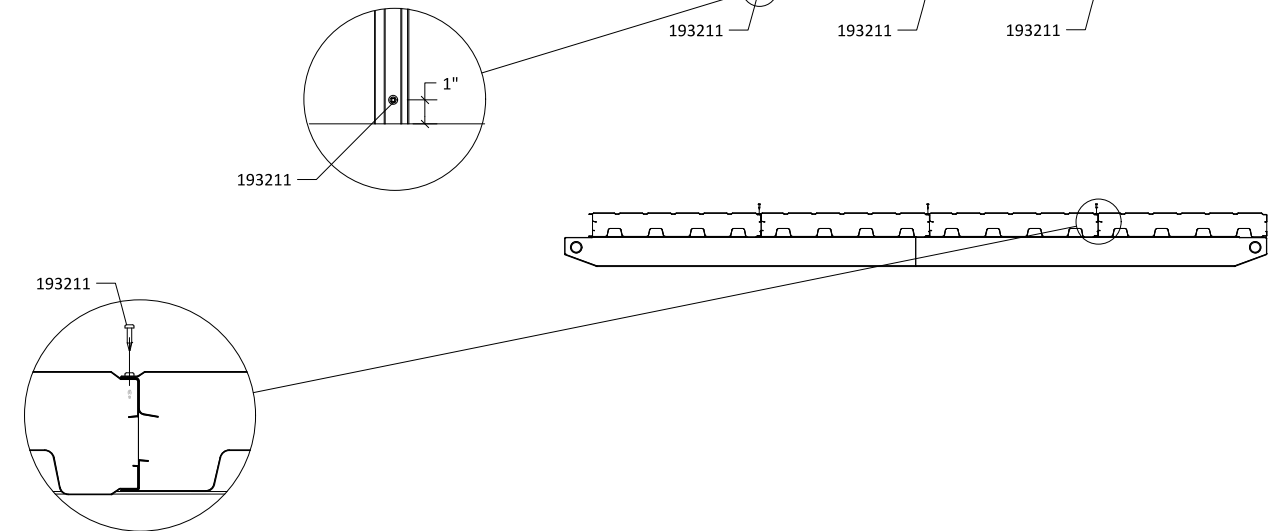
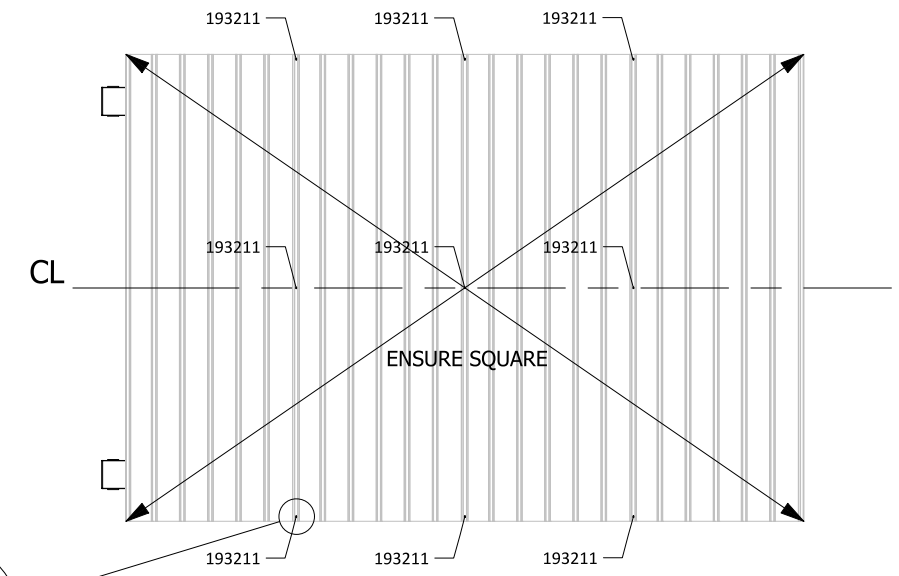
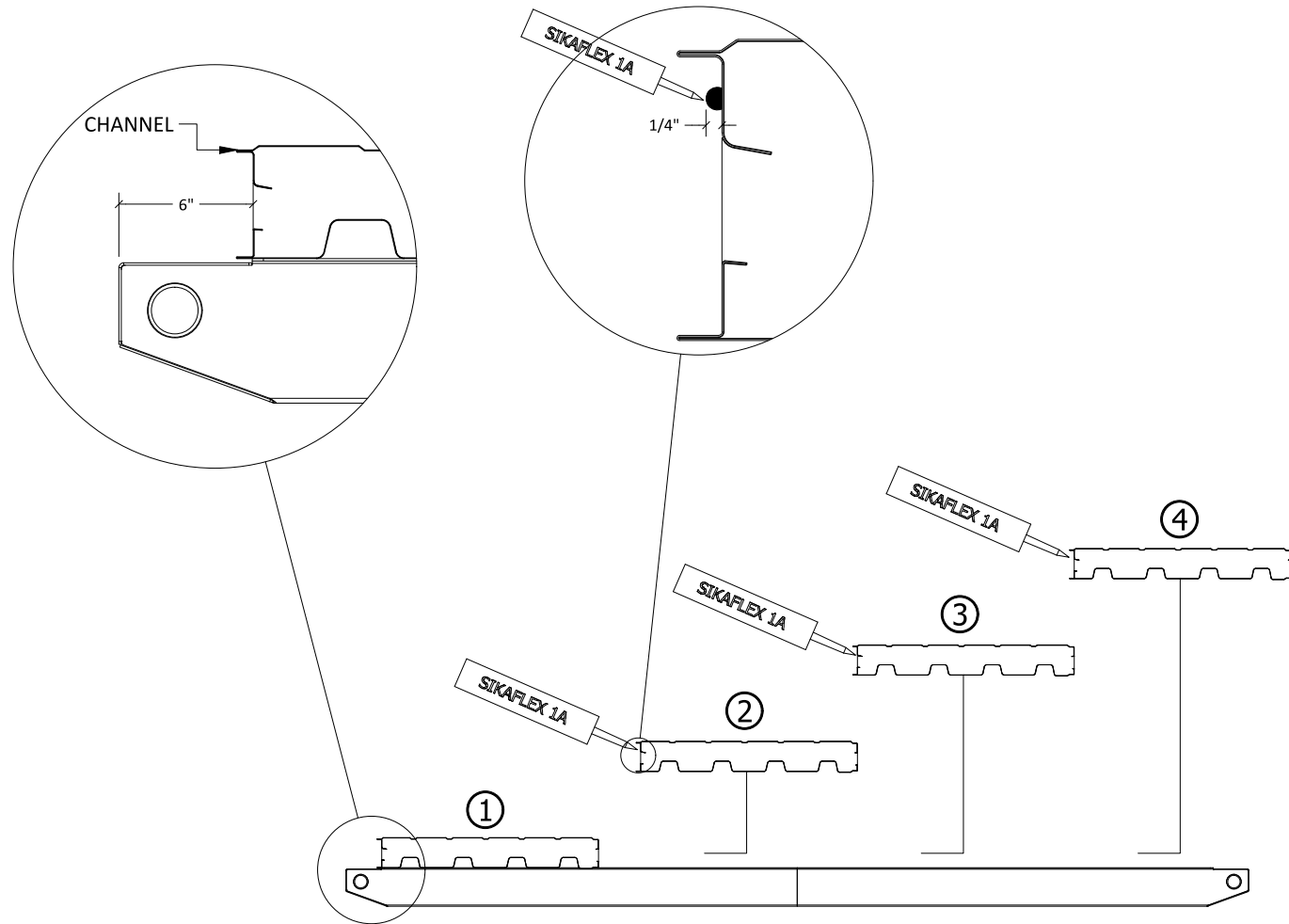
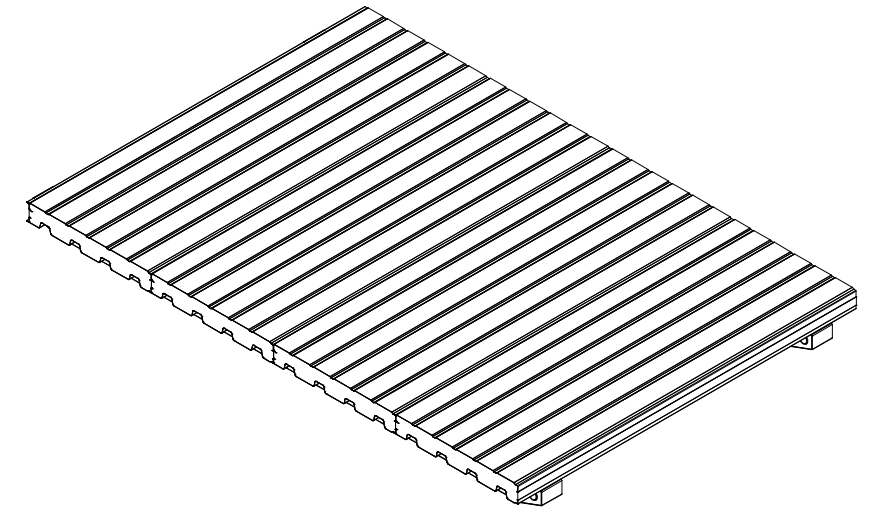



193202(X24)
(1/4"X6" TEK SCREW)

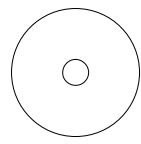

193228(X32)
(3/8" FLAT WASHER)

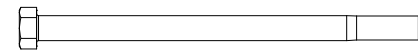

193226(X8)
(3/8"X6" BOLT)



193227(X8)
(3/8" LOCK NUT)

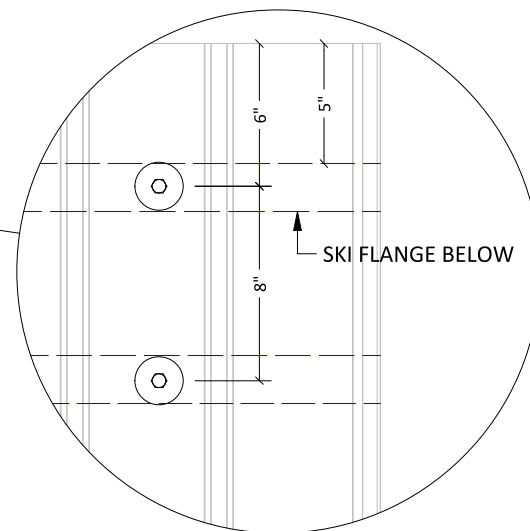
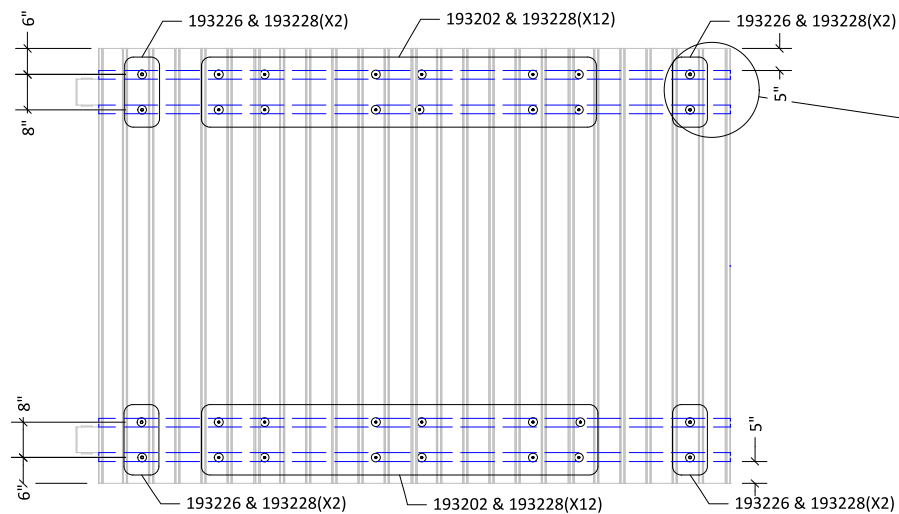
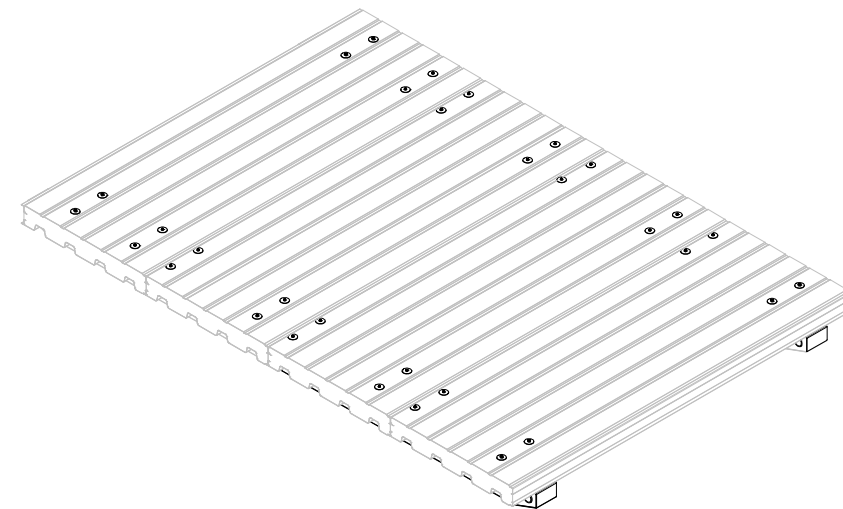
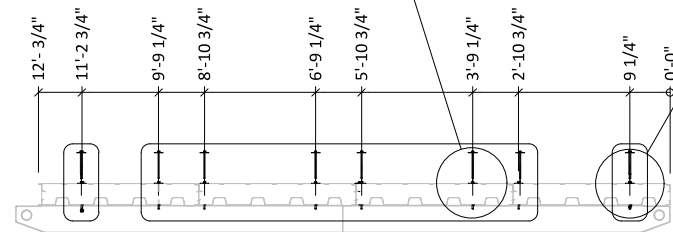
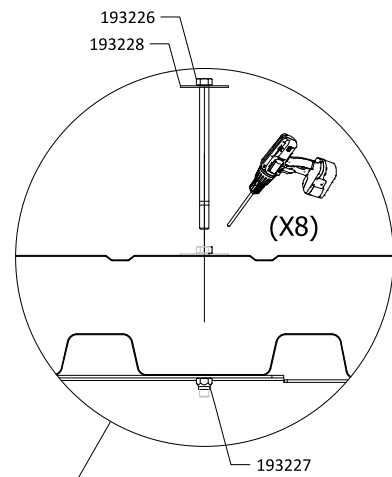
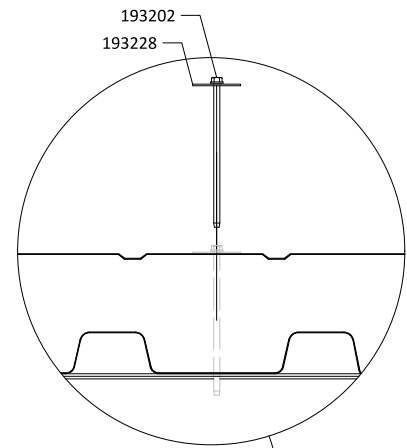
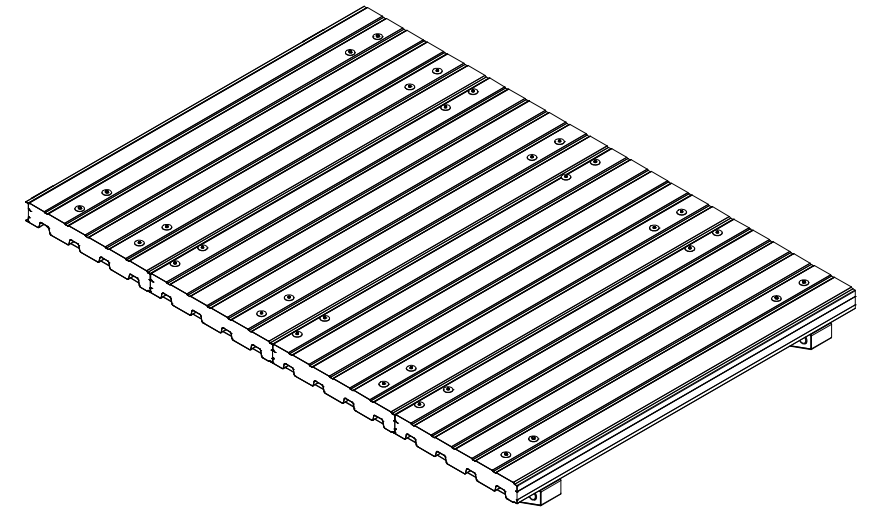

192610(X3)
(FLOOR CHANNEL 88.5")

192612(X1)
(FLOOR CHANNEL 88.5" FRONT)

192611(X2)
(FLOOR CHANNEL 55.25")

193218(X39)
(#8X3/4" POINTED SCREW)

SIKAFLEX 1A

192522
(SIKAFLEX 1A)

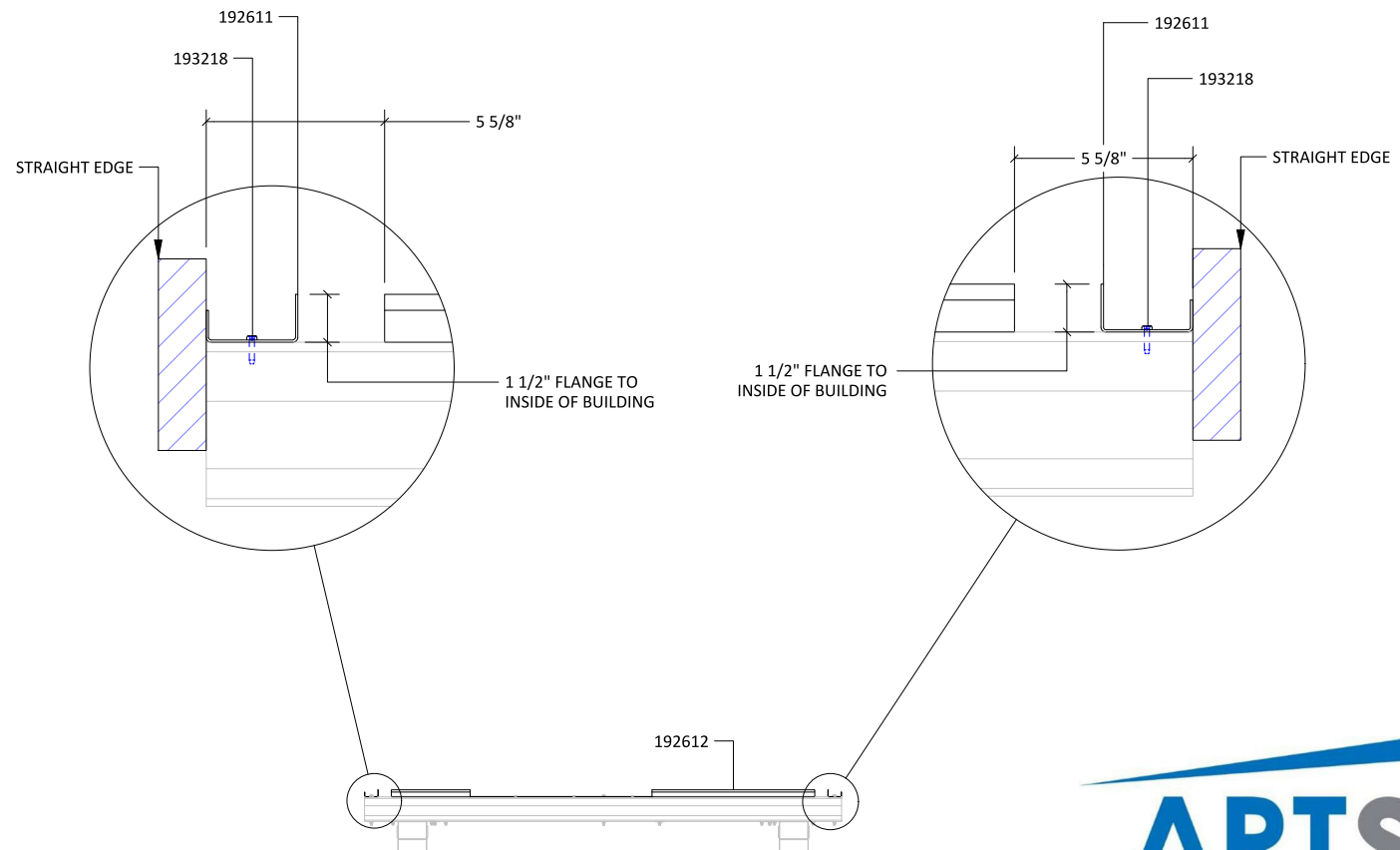
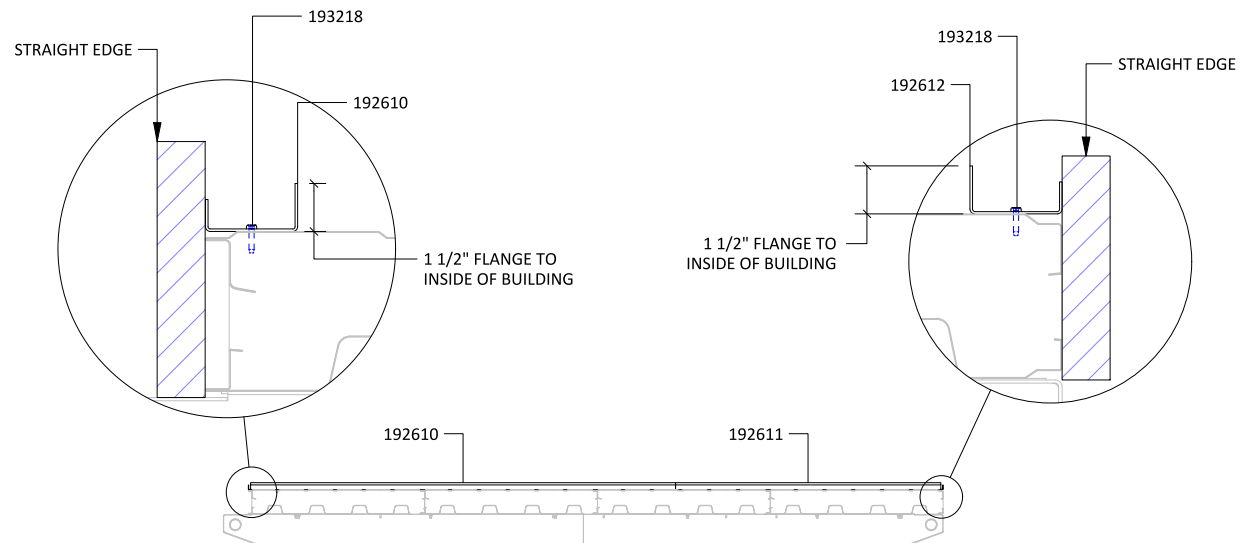
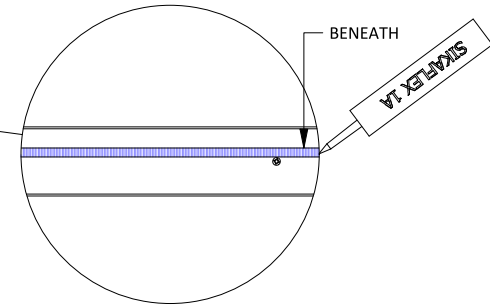
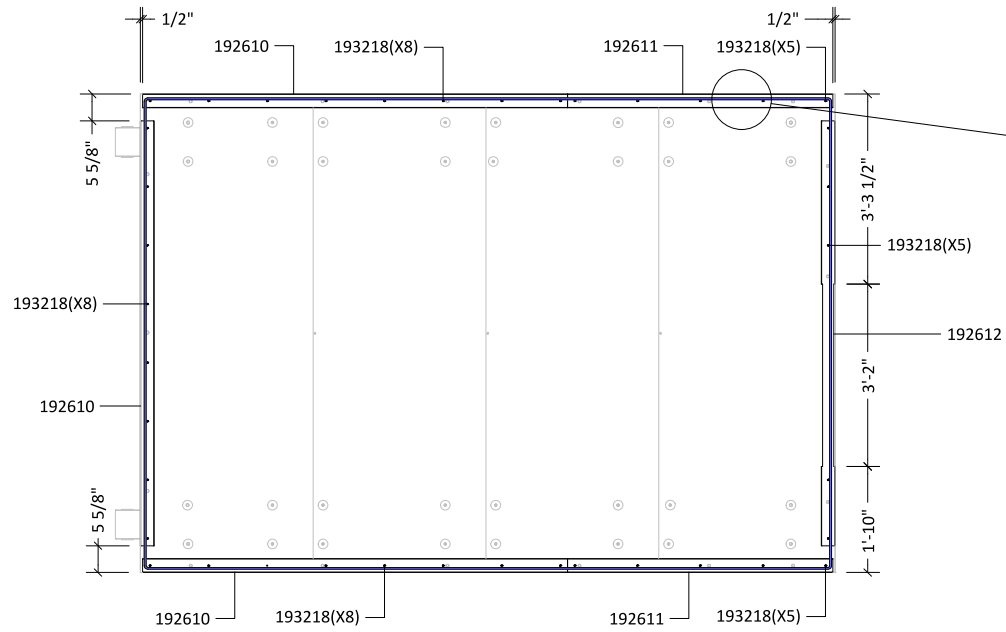
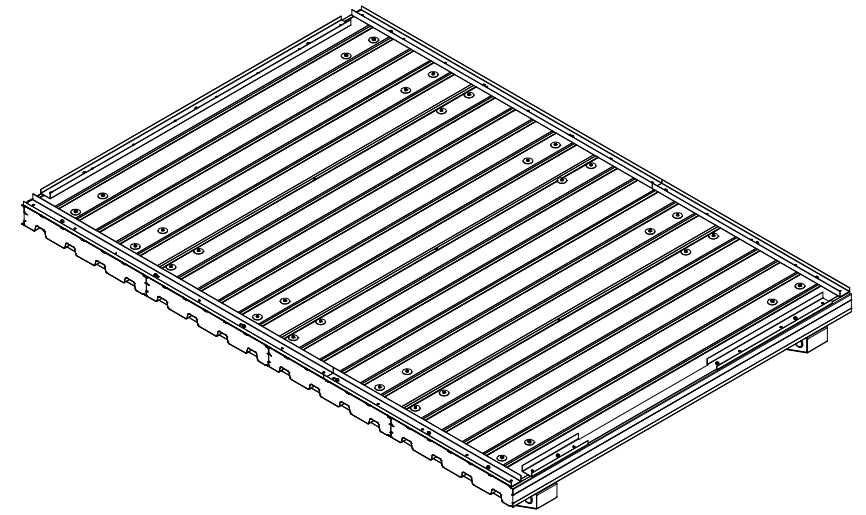

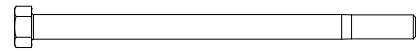

193226(X18)
(3/8"X6" BOLT)



193227(X18)
(3/8" LOCK NUT)

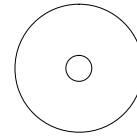

193228(X18)
(3/8" FLAT WASHER)

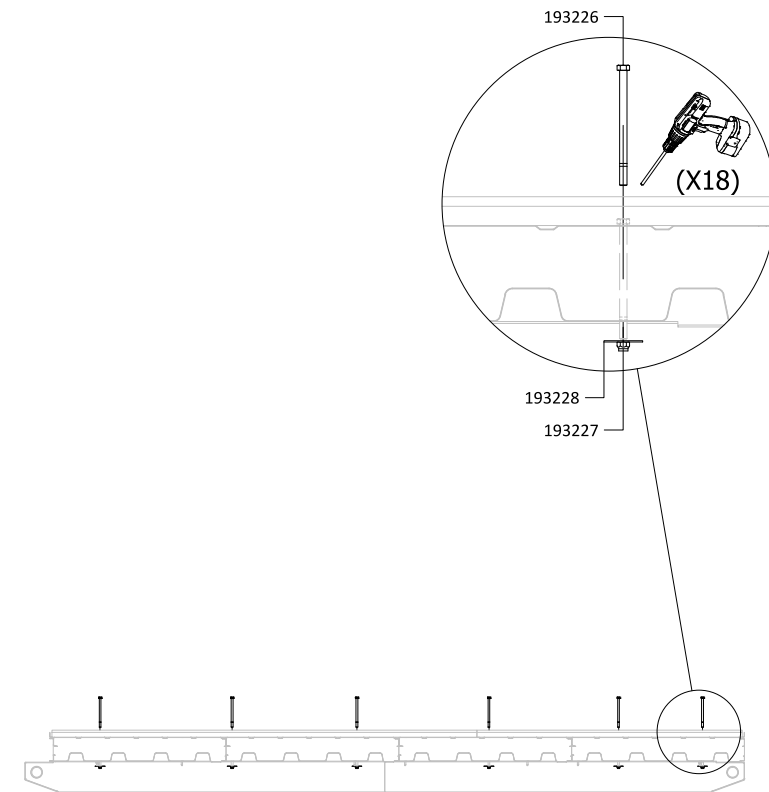
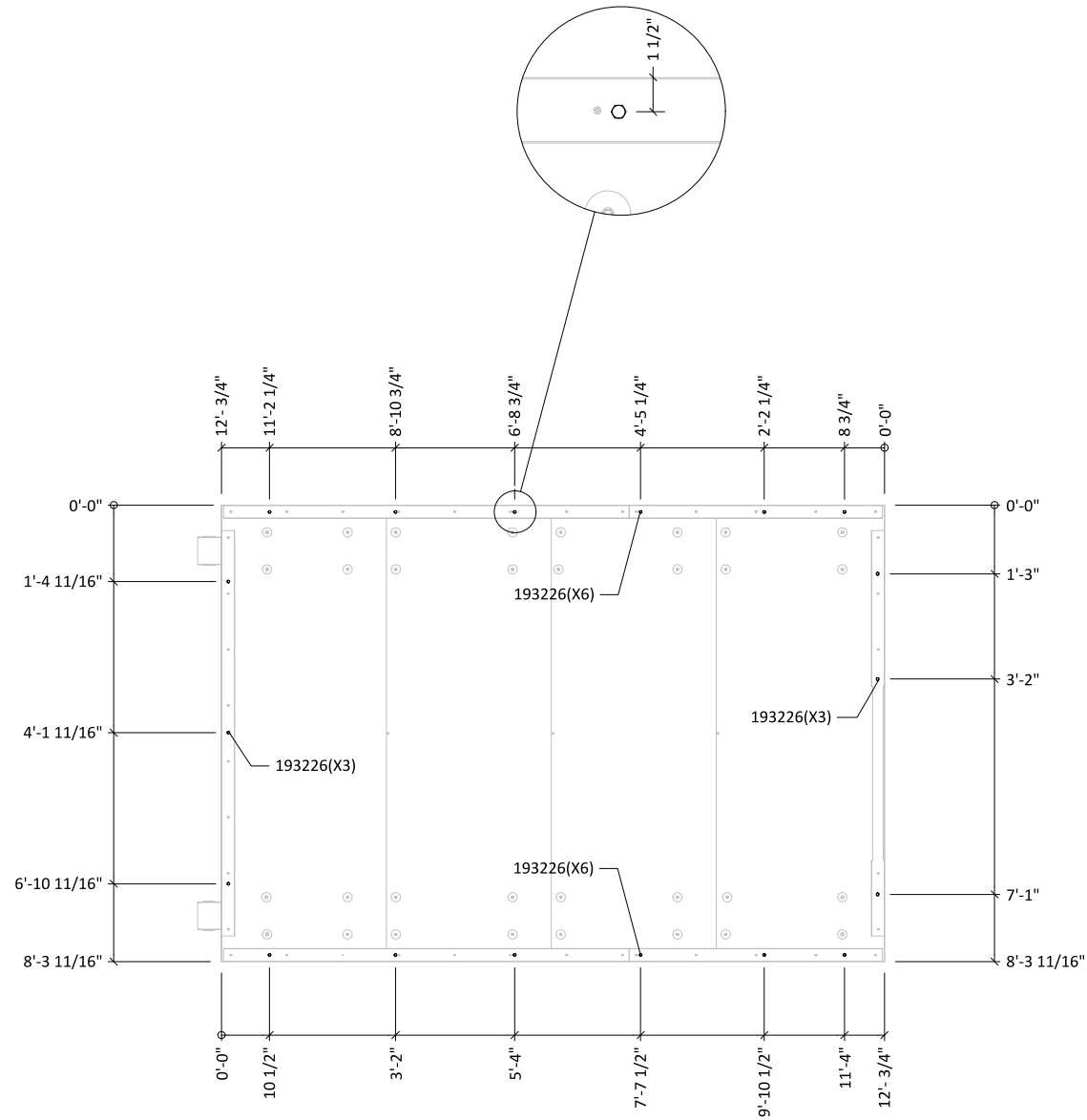
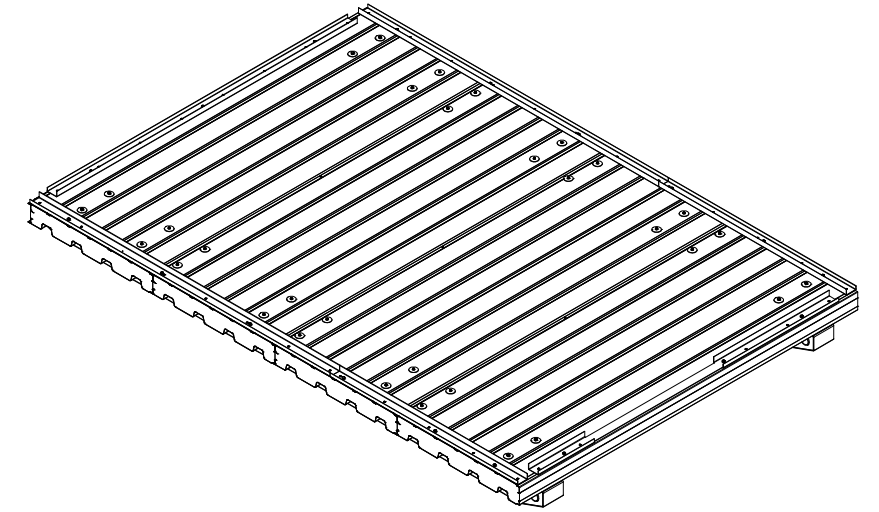

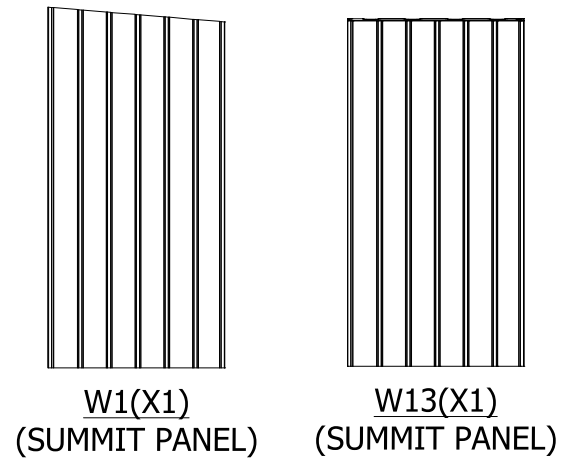

192613(X1)
(ANGLE 72")

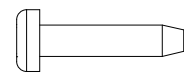

193218(X20)
(#8X3/4" POINTED SCREW)

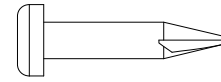

193211(X7)
(#10X3/4 DRILLING SCREW)



192522
(SIKAFLEX 1A)

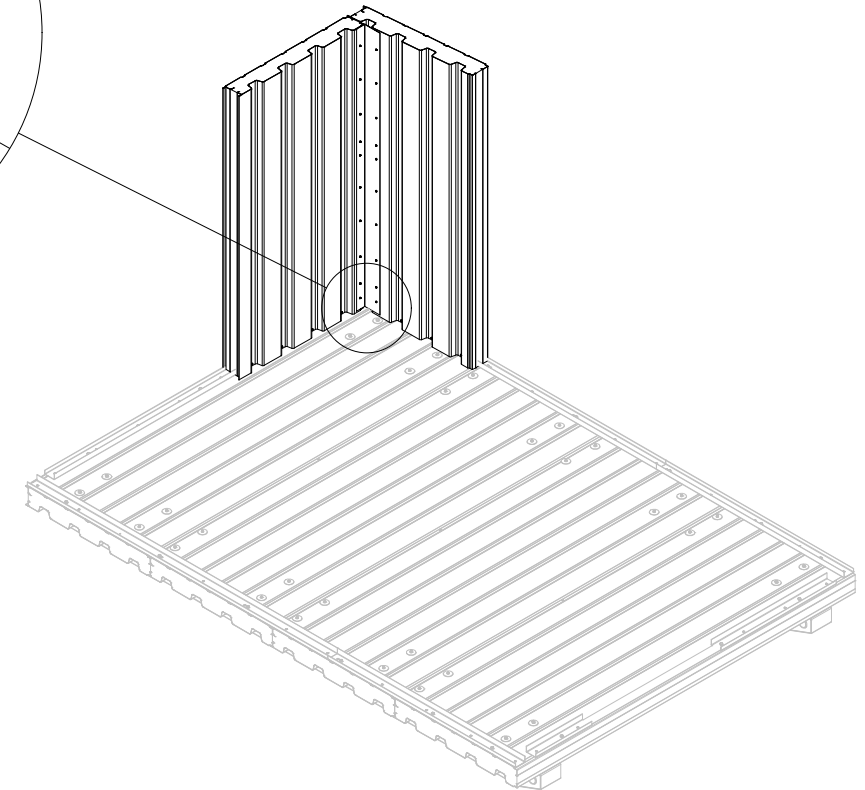
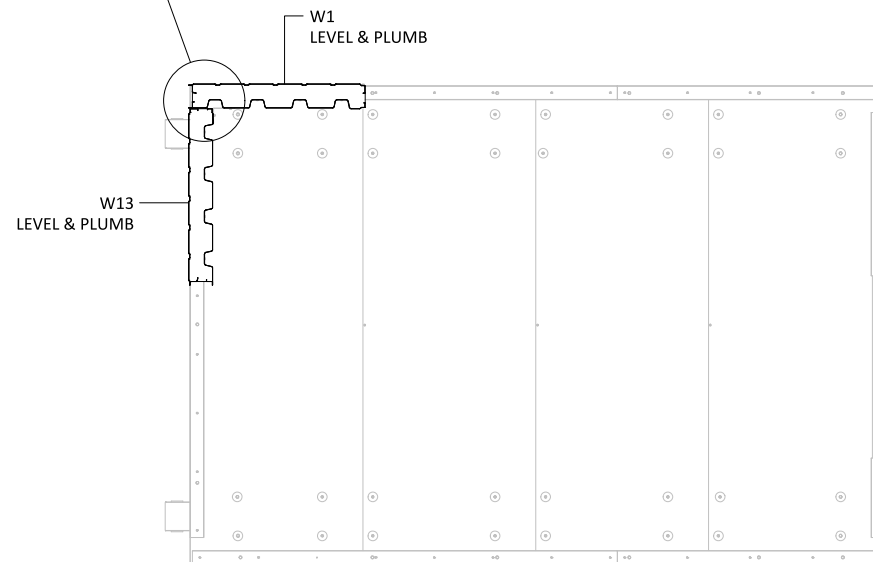
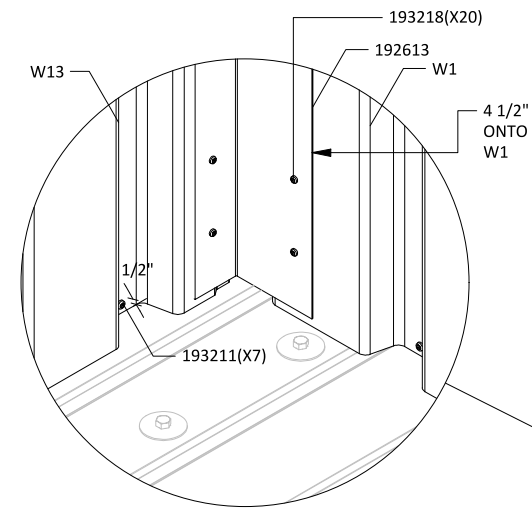
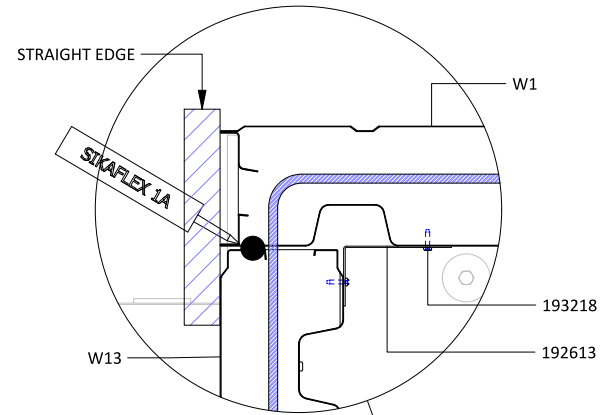
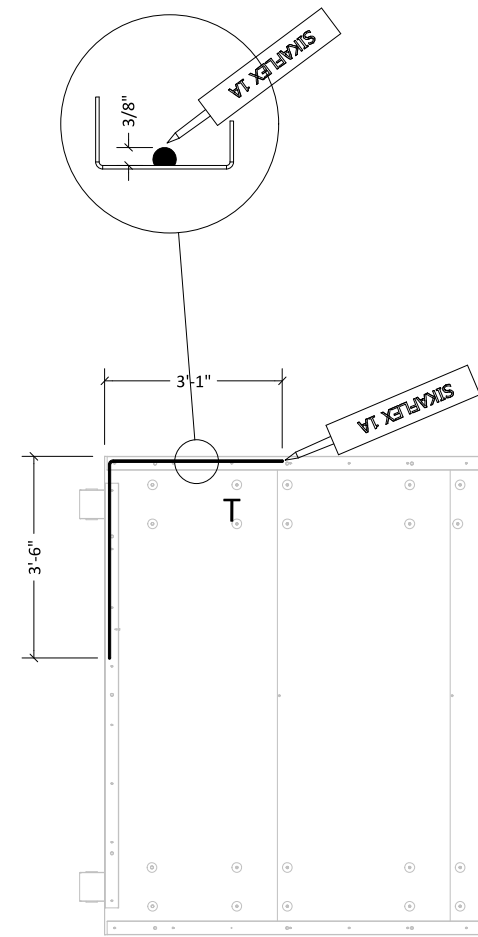
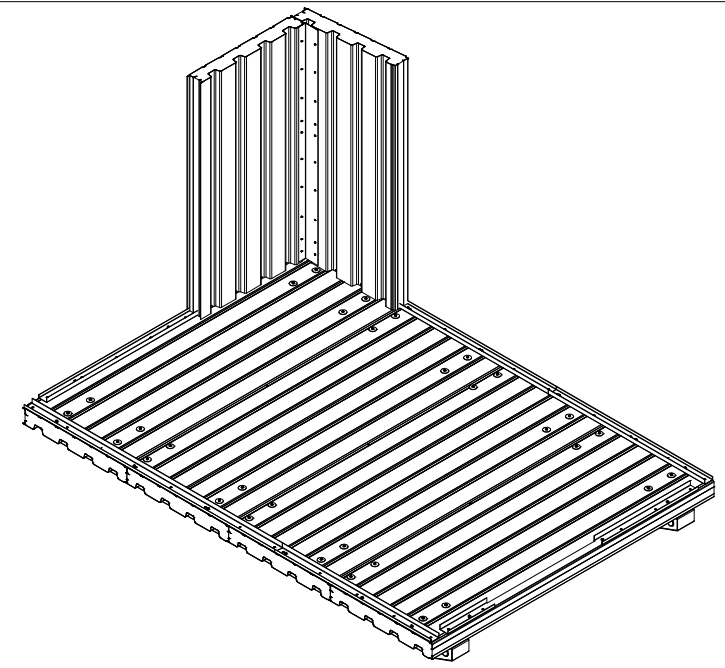

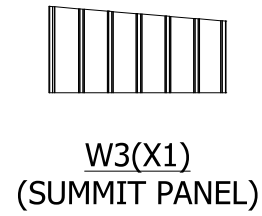

W3(X1)
(SUMMIT PANEL)

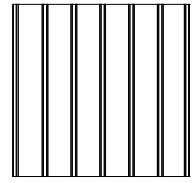

W2(X1)
(SUMMIT PANEL)

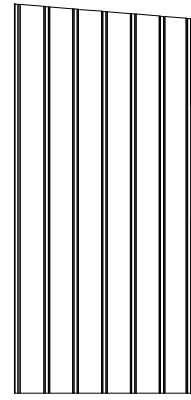

W4(X1)
(SUMMIT PANEL)

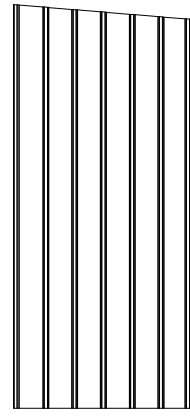

W5(X1)
(SUMMIT PANEL)

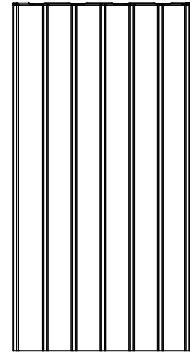

W13(X1)
(SUMMIT PANEL)

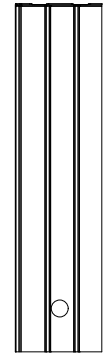

W14(X1)
(SUMMIT PANEL)

SIKAFLEX 1A

192522
(SIKAFLEX 1A)

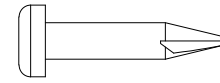

193211(X33)
(#10x3/4 DRILLING SCREW)

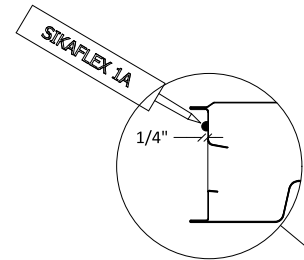
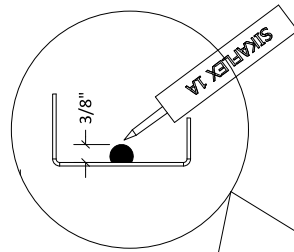
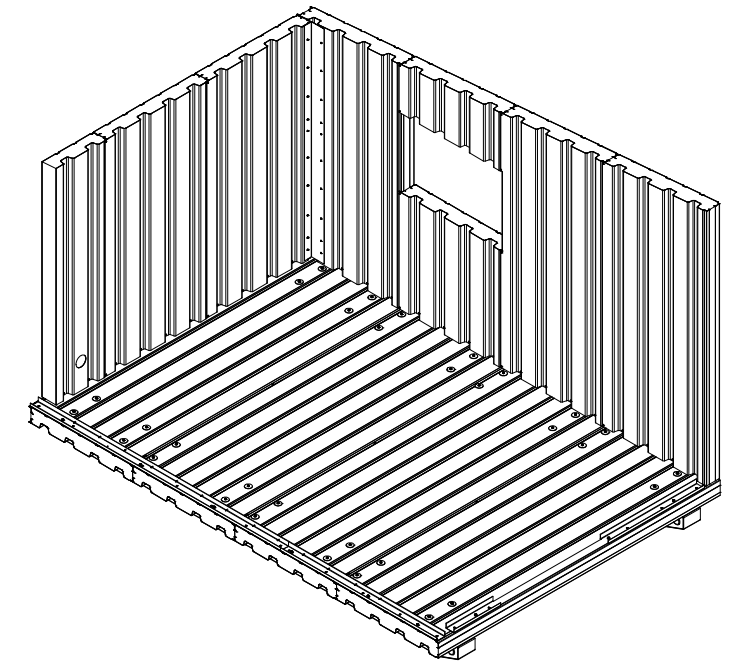

193211
ALL INSIDE JOINTS ONLY

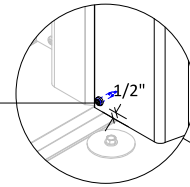

193211
ALL INSIDE JOINTS

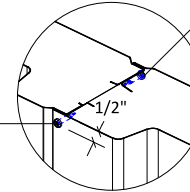

193211
OUTSIDE W3 ONLY

193211
ALL INSIDE JOINTS

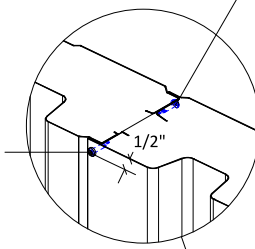

193211
OUTSIDE W3 ONLY

193211
ALL DEEP
CORRUGATION

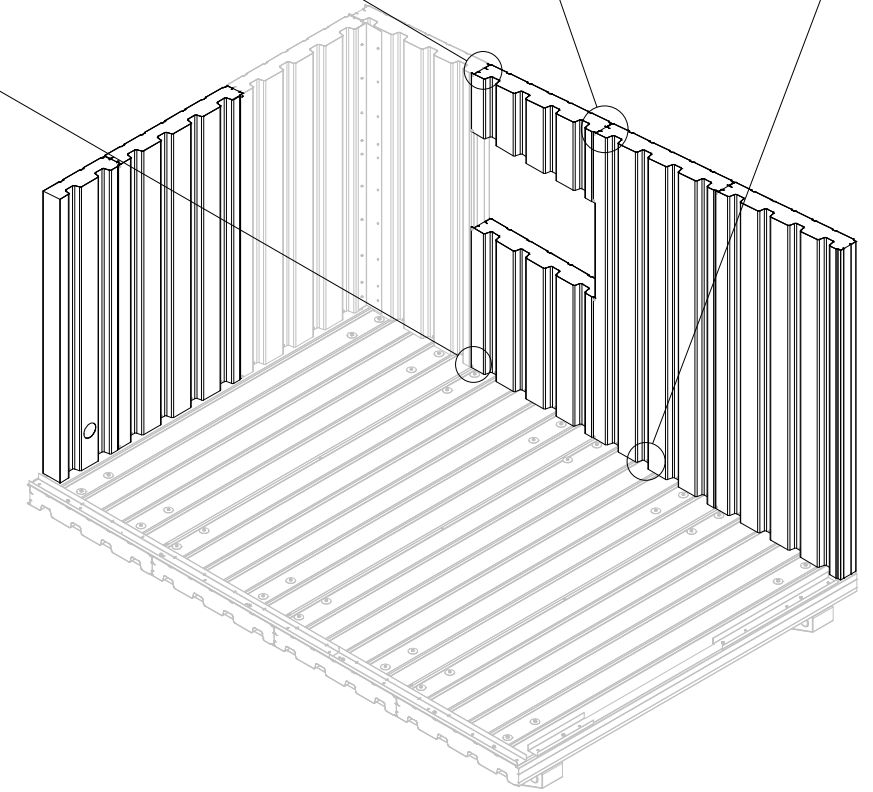
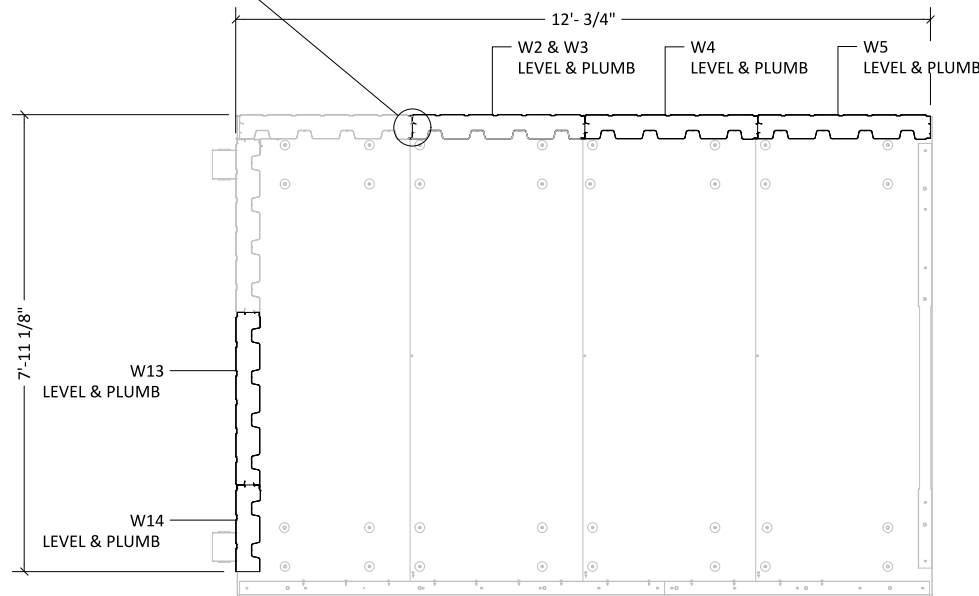
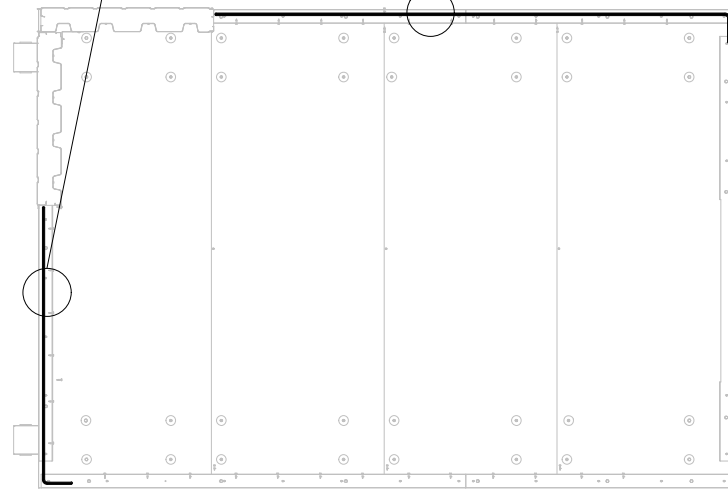
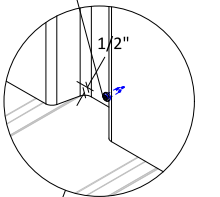

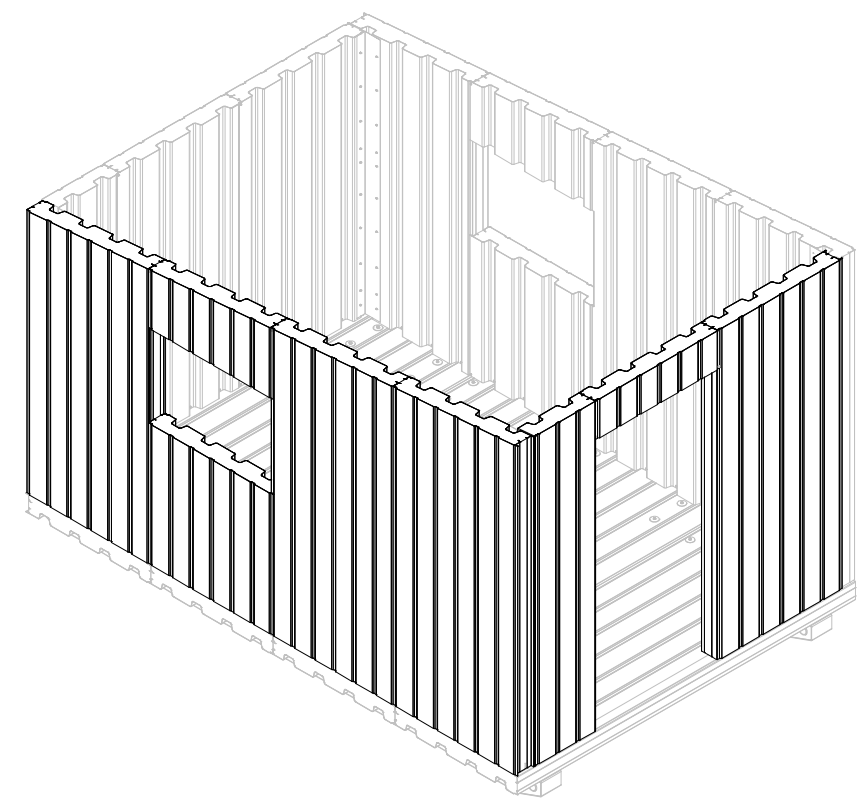
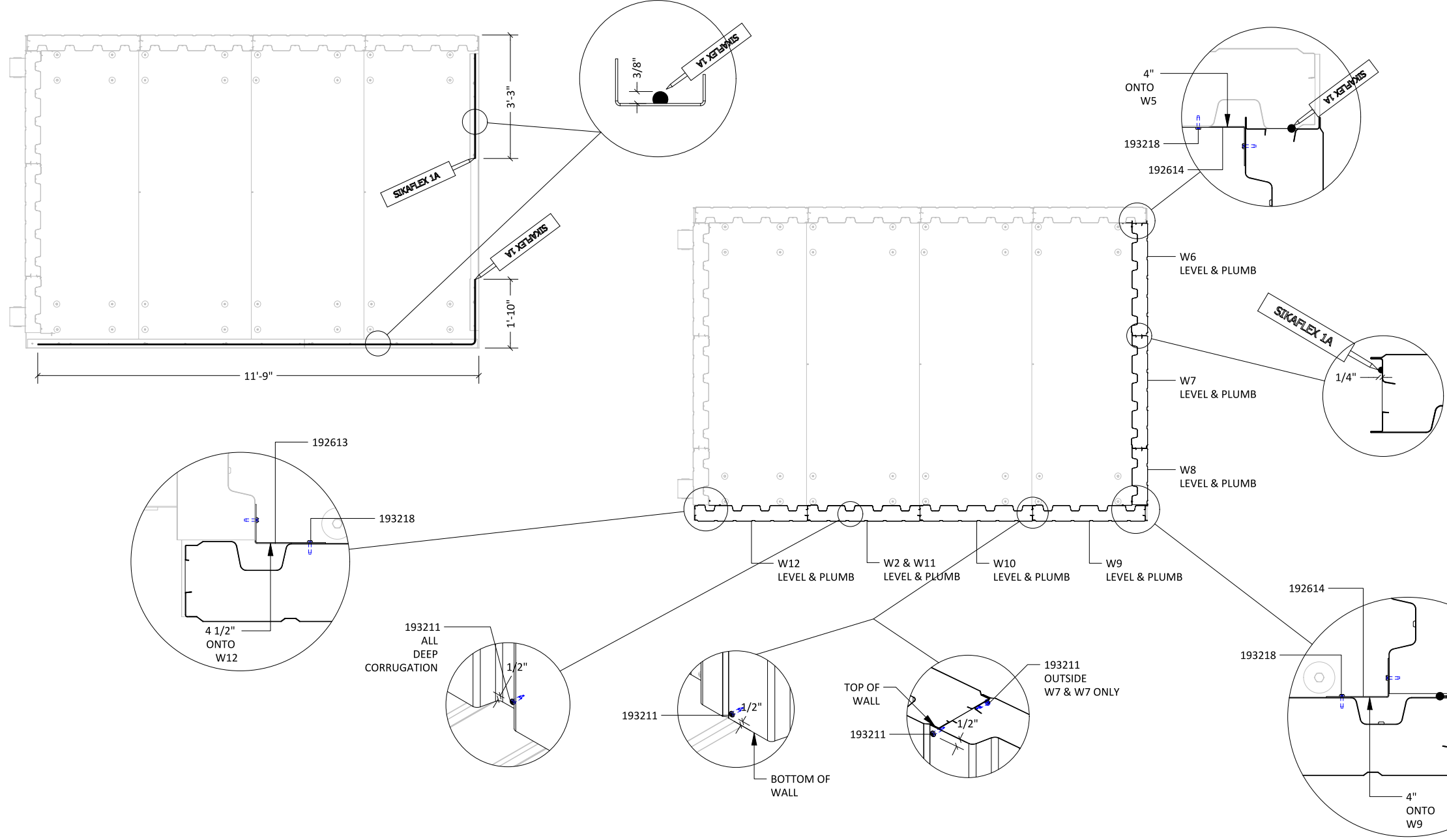
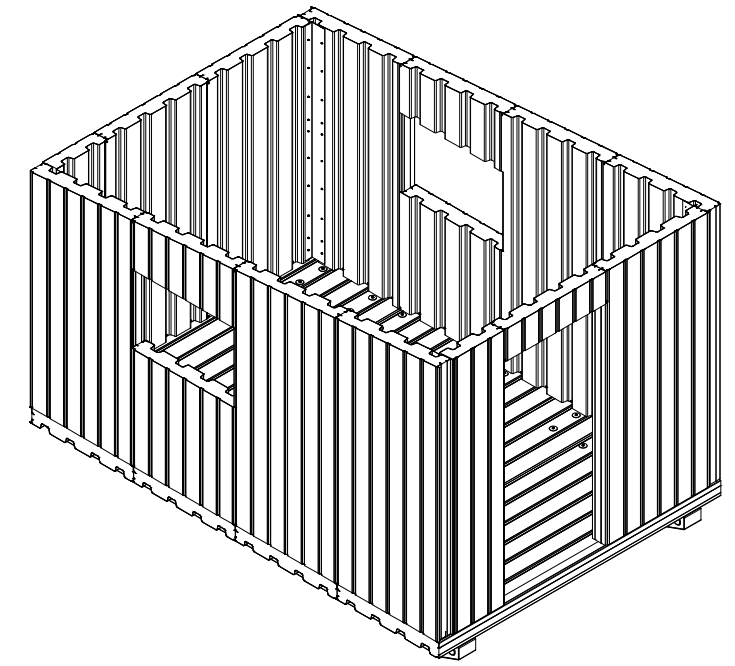
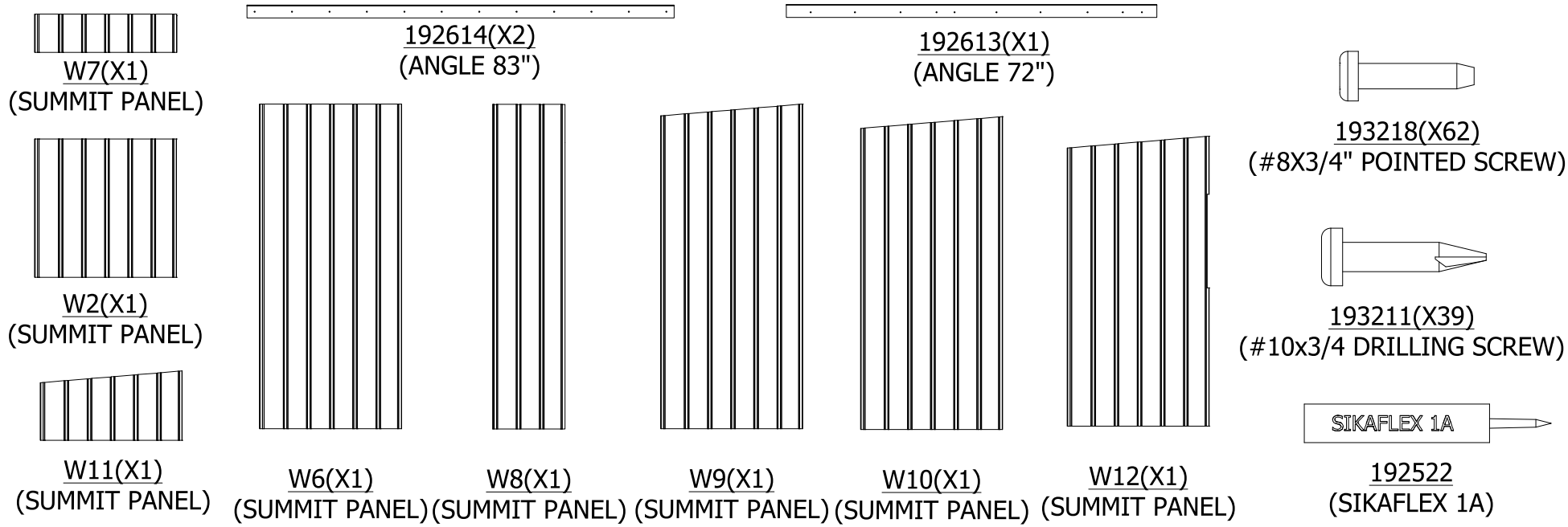

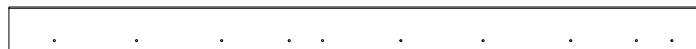

192613(X2)
(ANGLE 72")



192615(X1)
(FRONT ROOF ANGLE)

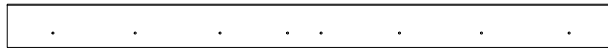

192617(X2)
(ANGLE 62.75")



192616(X1)
(BACK ROOF ANGLE 90")

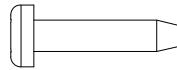

193218(X58)
(#8X3/4" POINTED SCREW)



192522
(SIKAFLEX 1A)

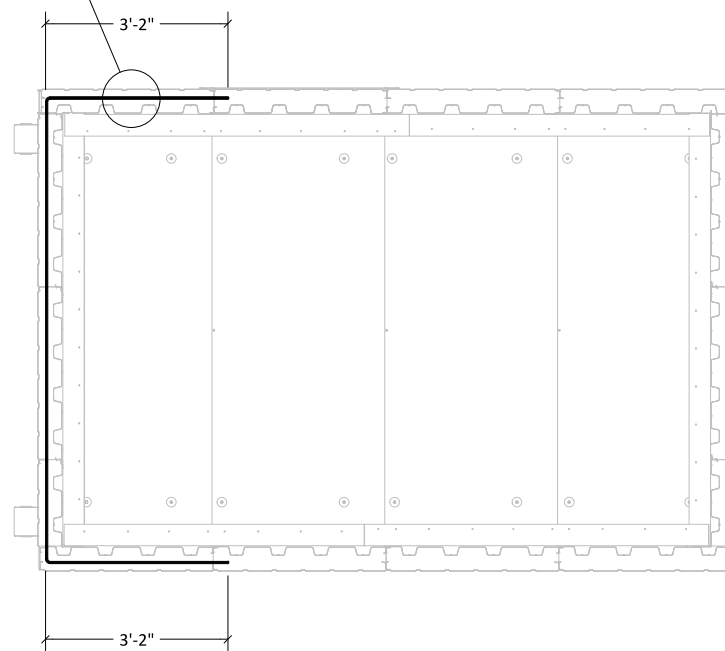
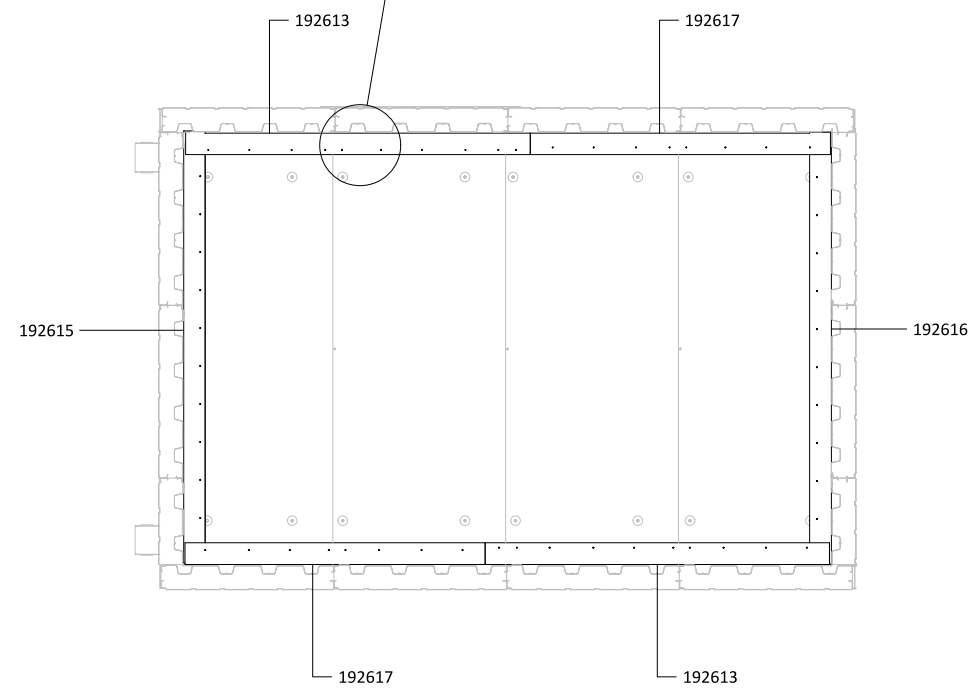
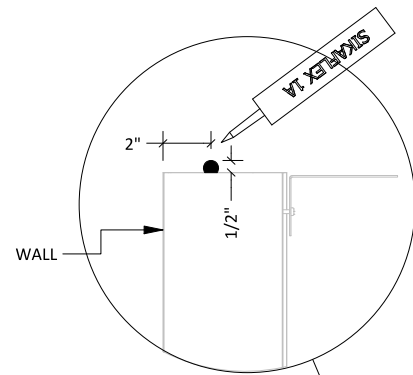
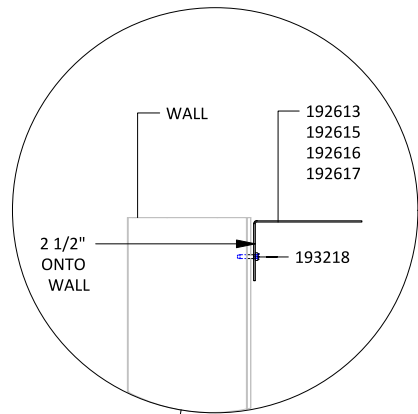
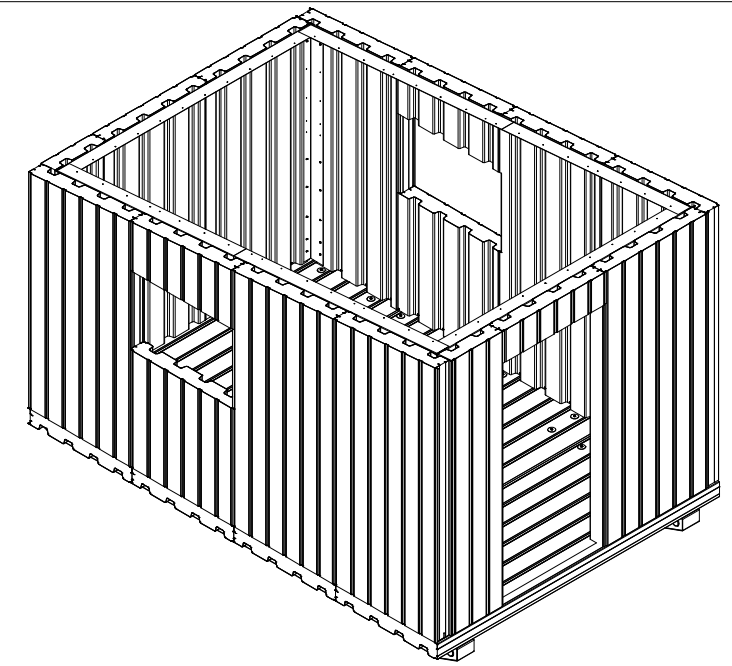

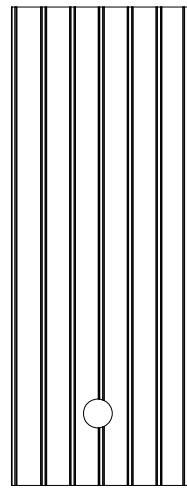

R2(X1)
(SUMMIT PANEL)

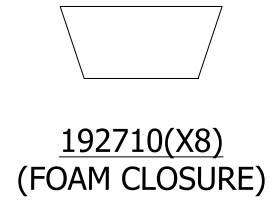

192710(X8)
(FOAM CLOSURE)

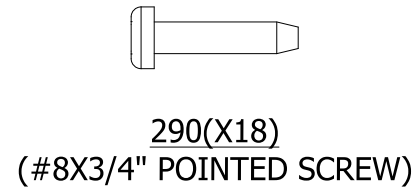

290(X18)
(#8X3/4" POINTED SCREW)



192522
(SIKAFLEX 1A)

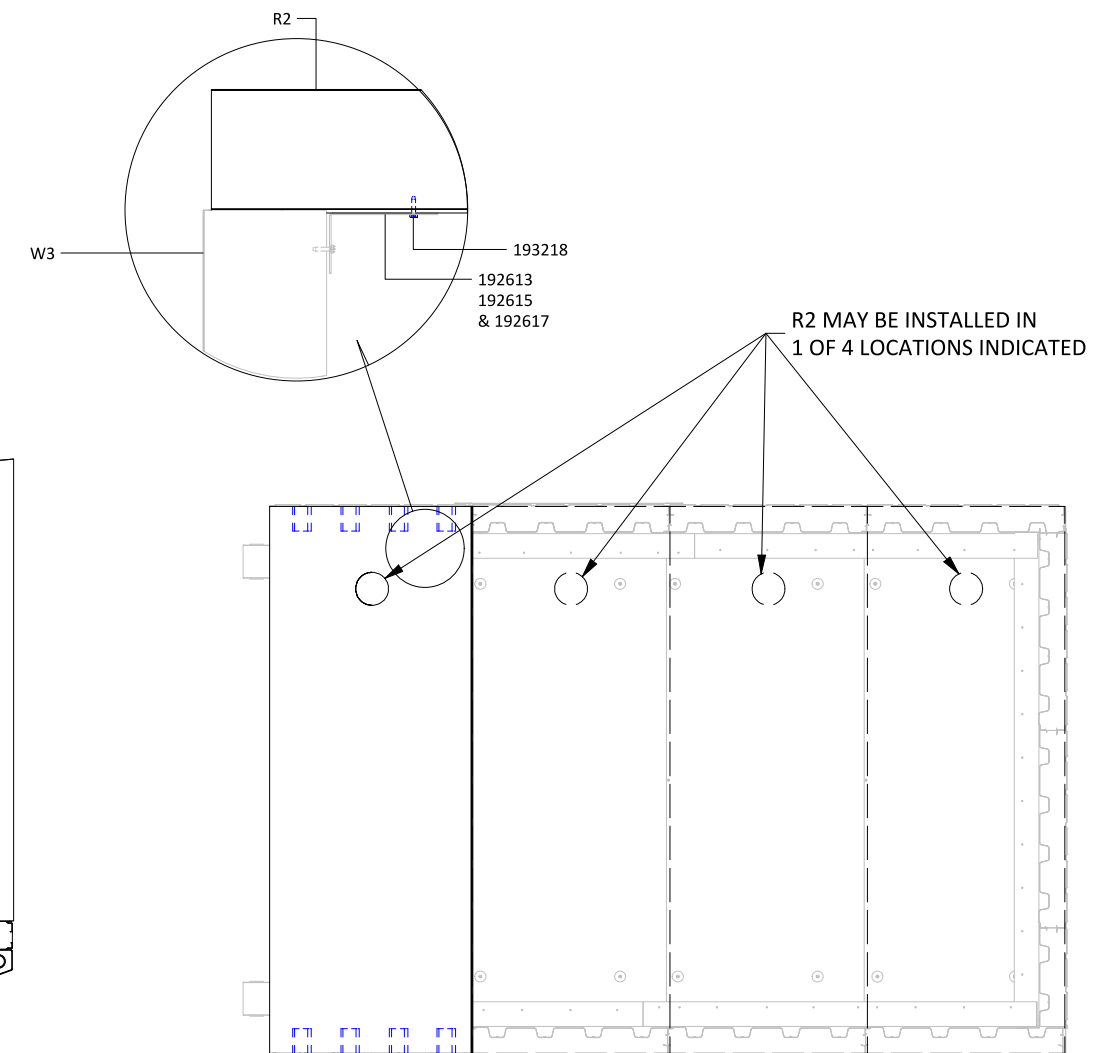
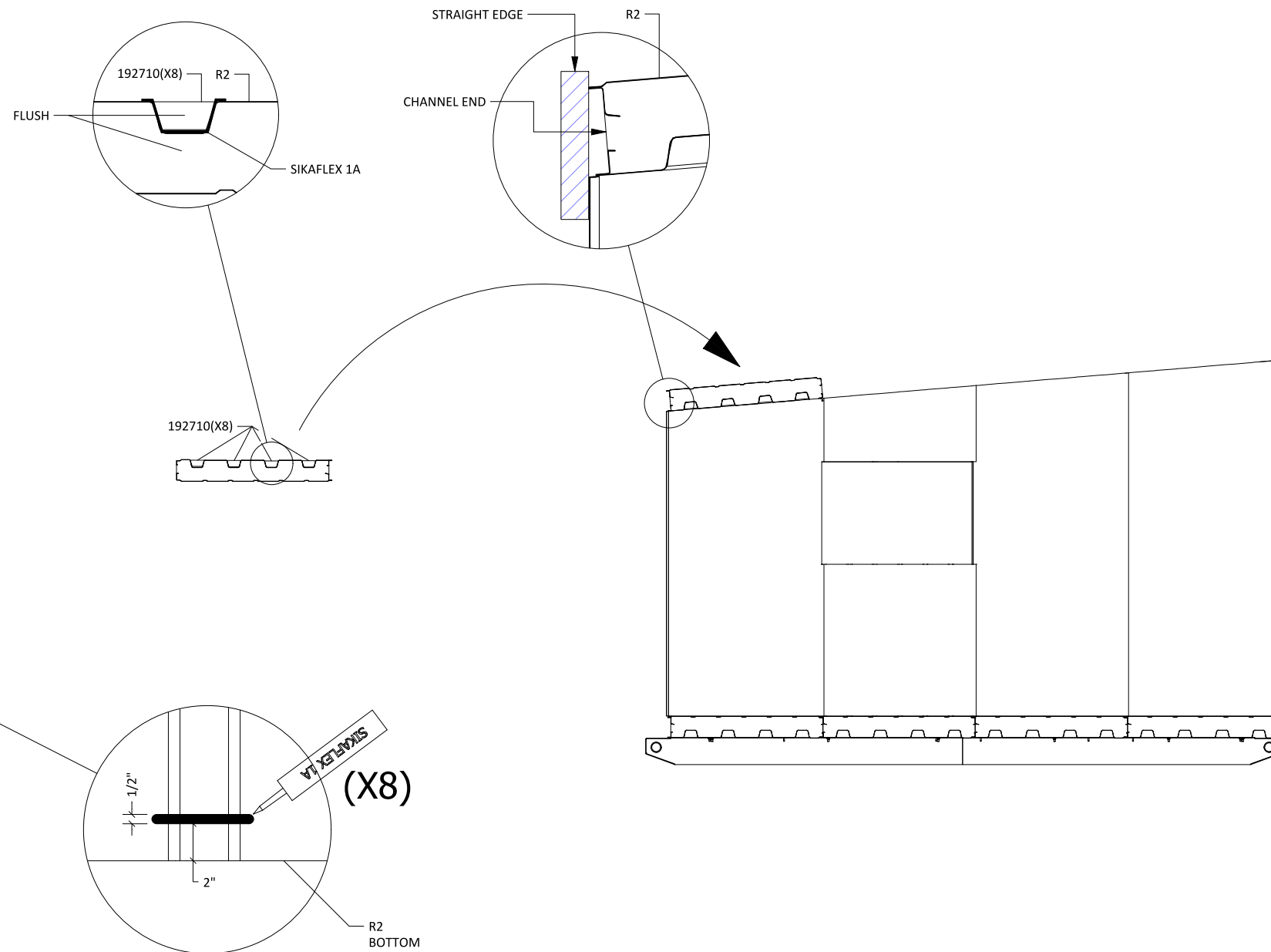
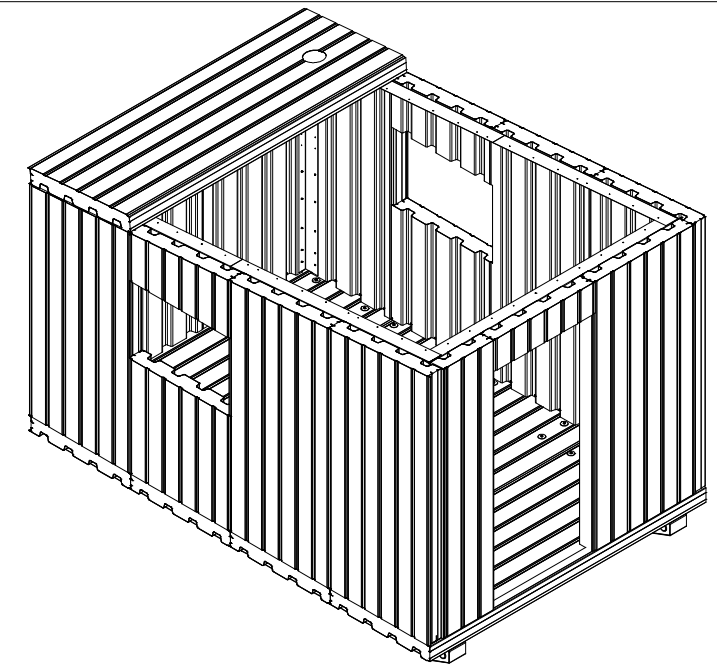

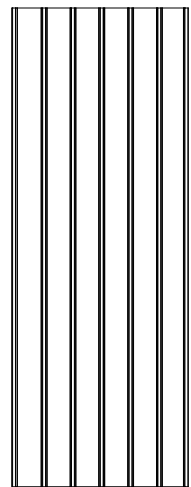

R1
(SUMMIT PANEL)

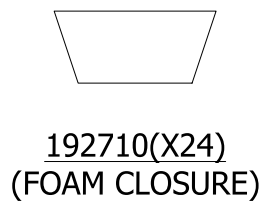

192710(X24)
(FOAM CLOSURE)

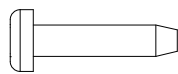

193218(X54)
(#8X3/4" POINTED SCREW)



192522
(SIKAFLEX 1A)

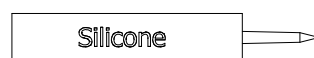

192527
(SILICONE)

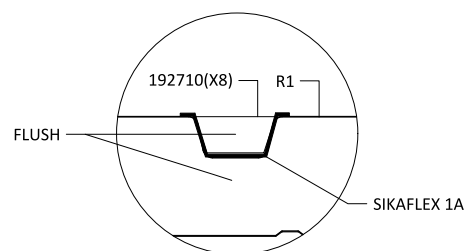
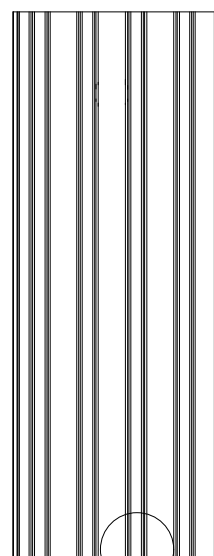
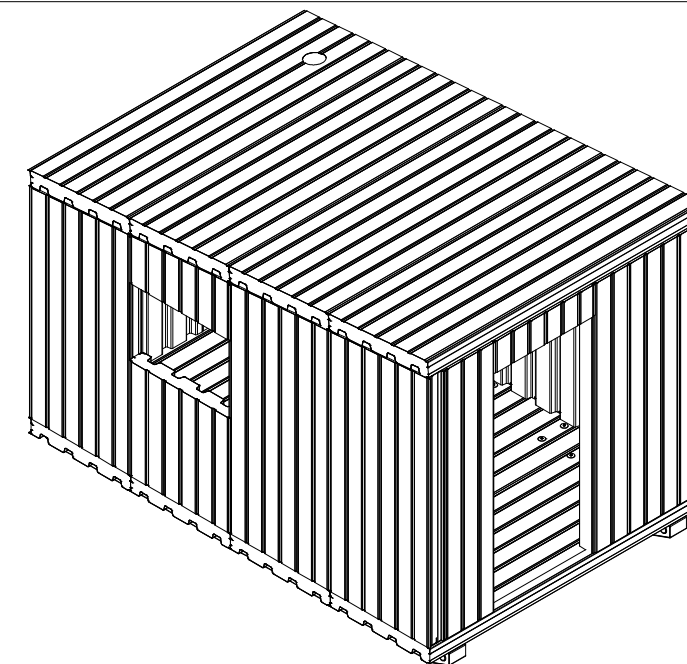

(X3)

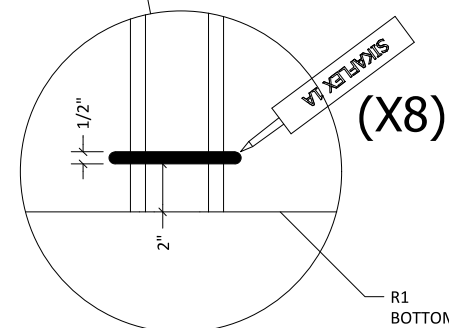
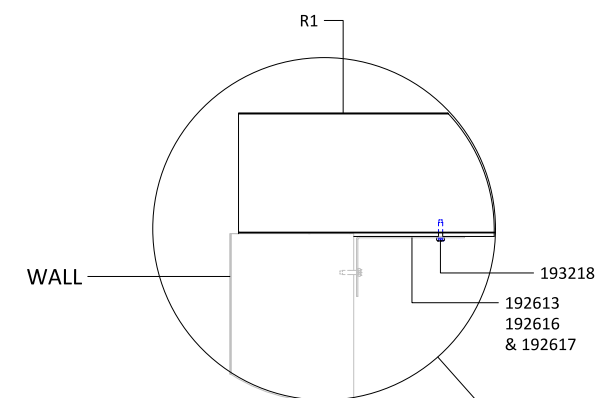
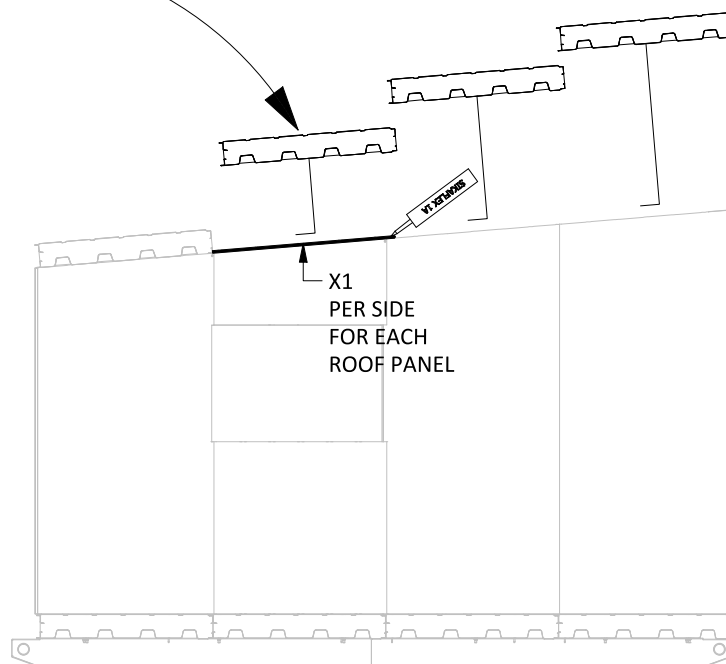
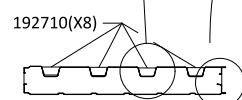

(X8)

R1
BOTTOM

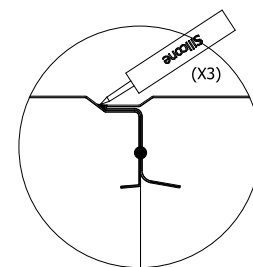
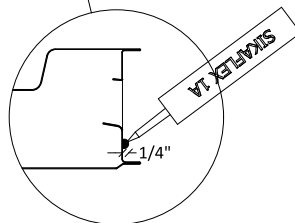

SECTION

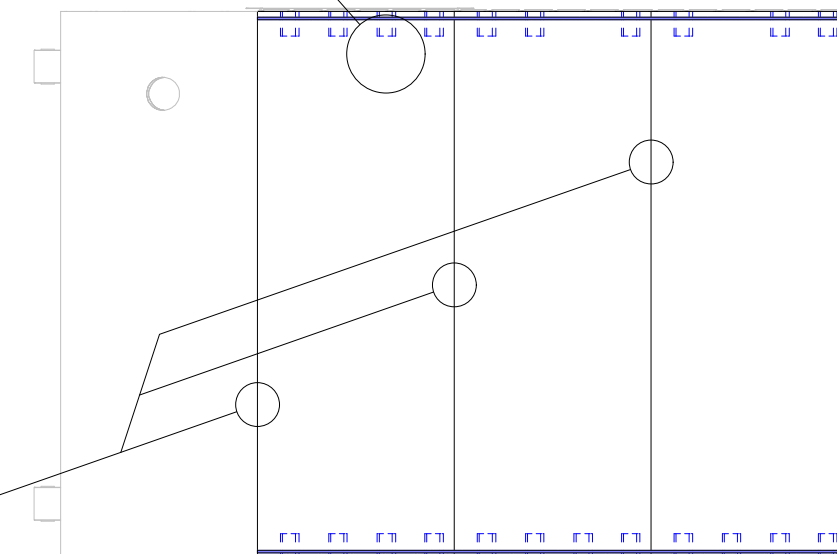

192595(X4)
(BASE TRIM)

193236(X75)
(#12X1 BLACK SCREW)

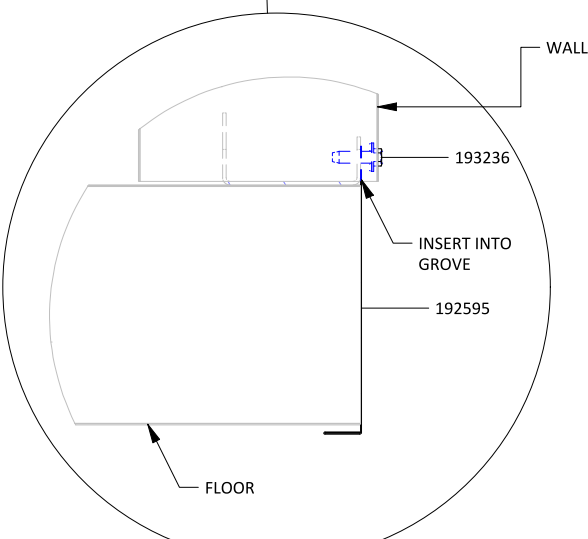
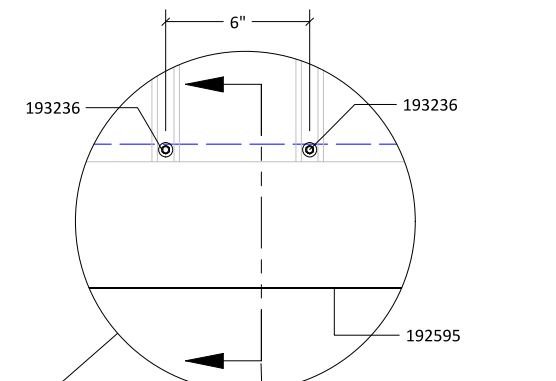
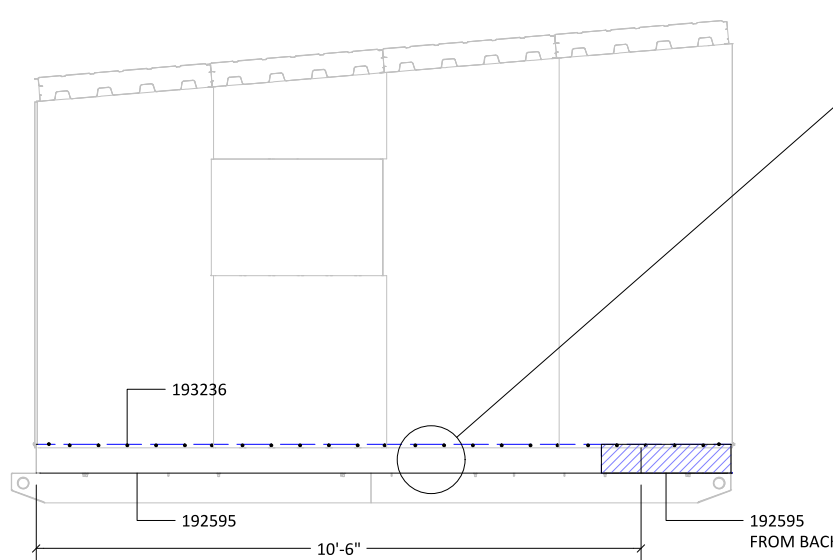
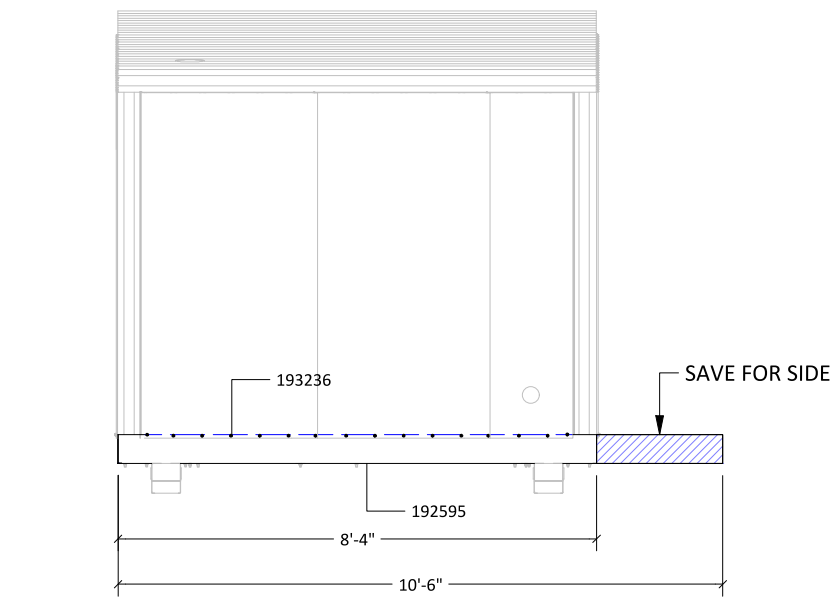
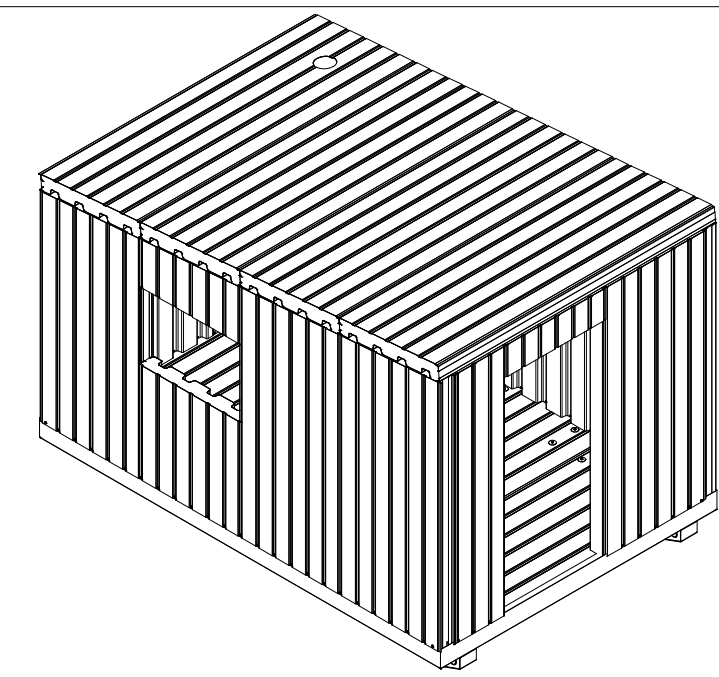

SECTION

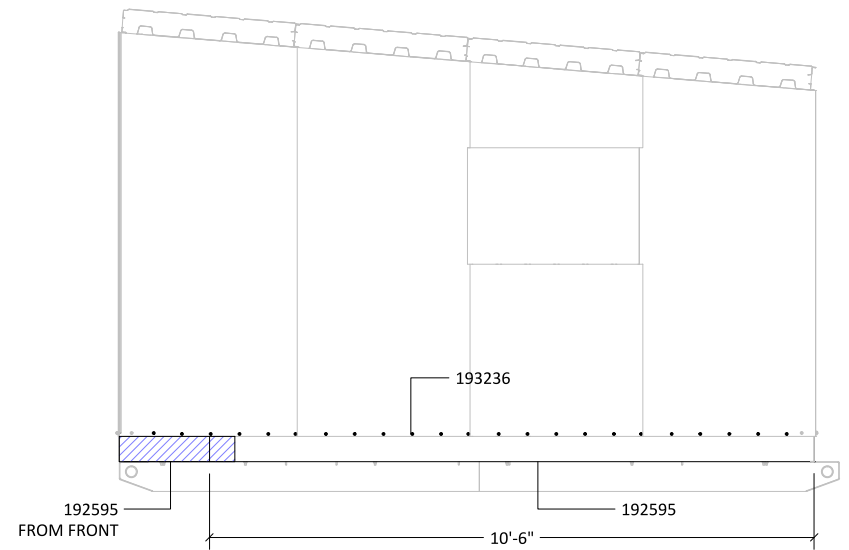
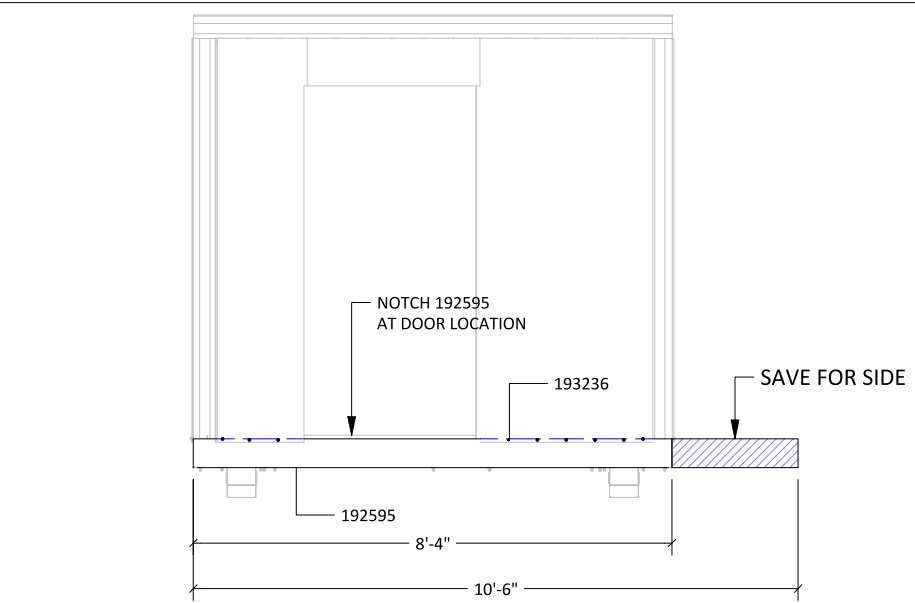

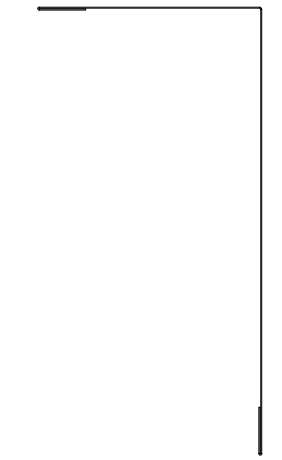

192594(X4)
(ICE SHACK TRIM)

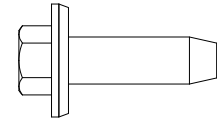

193236(X52)
(#12X1 BLACK SCREW)

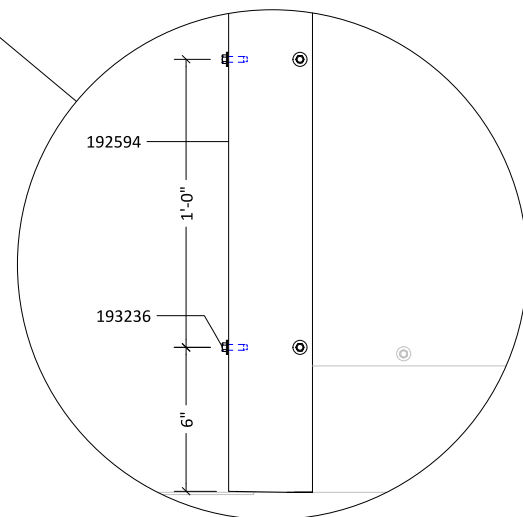
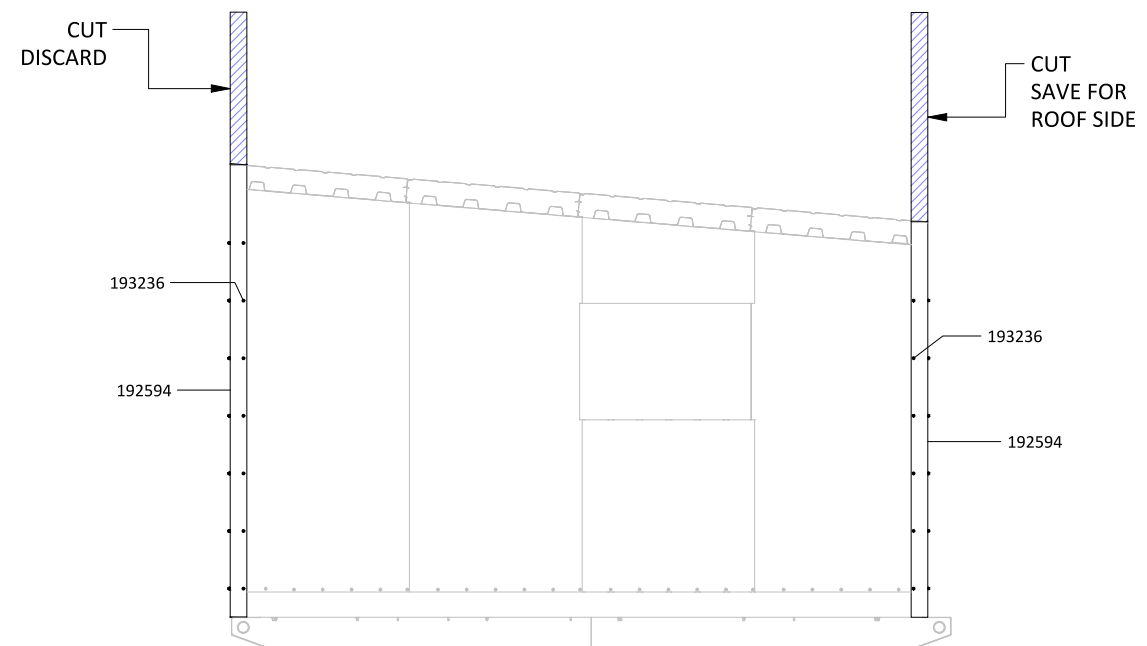
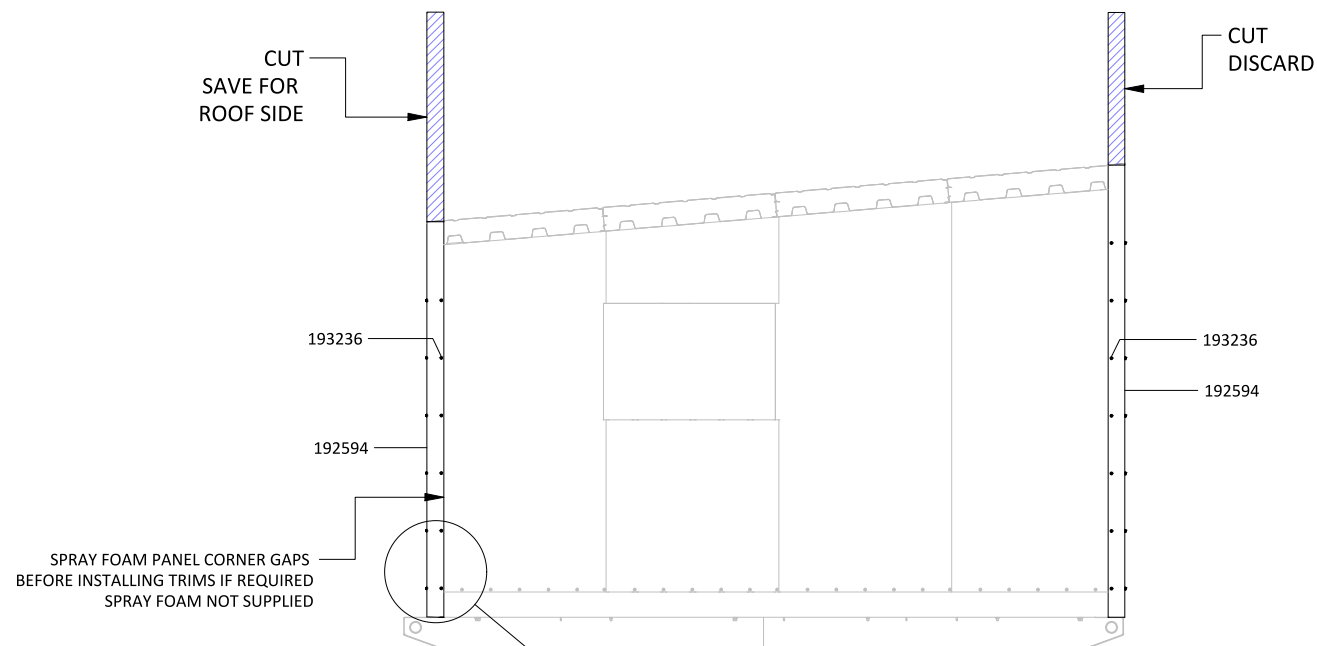
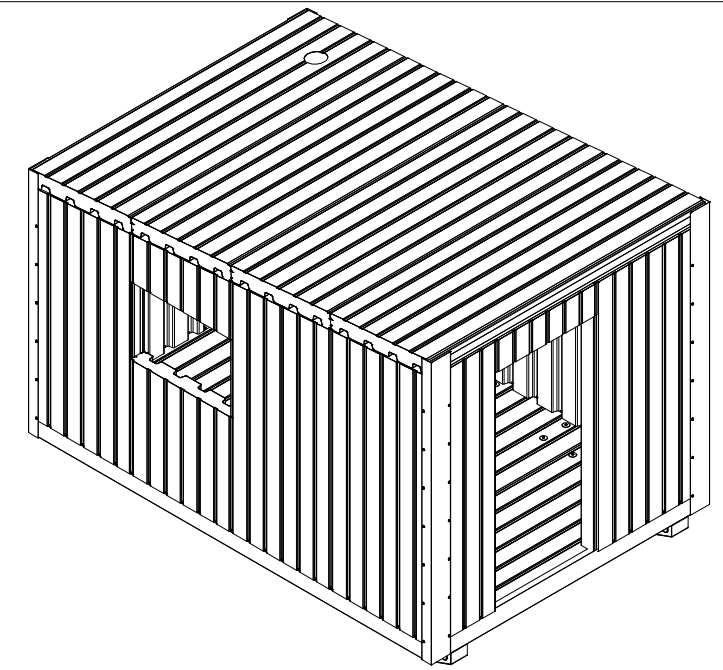

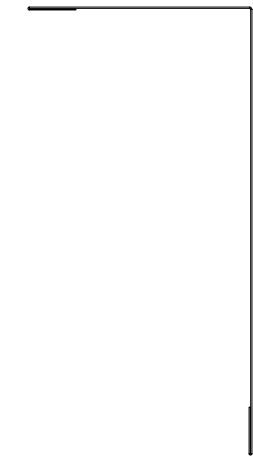

192594(X1)
(ICE SHACK TRIM)

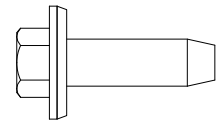

193236(X13)
(#12X1 BLACK SCREW)



192527
(SILICONE)

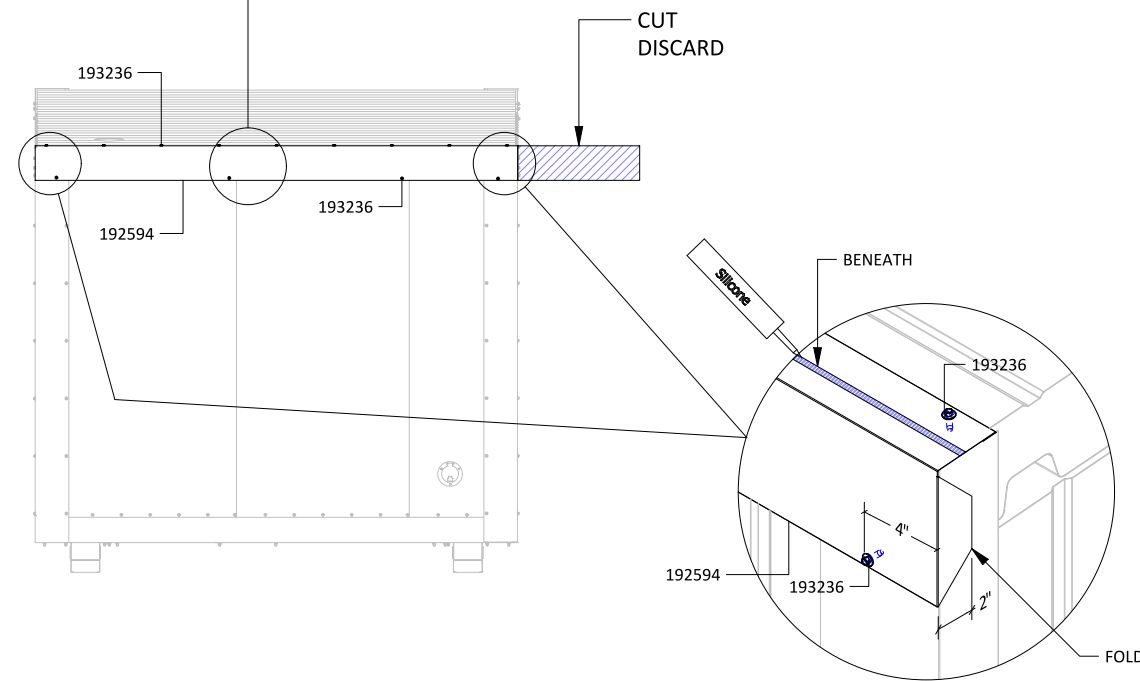
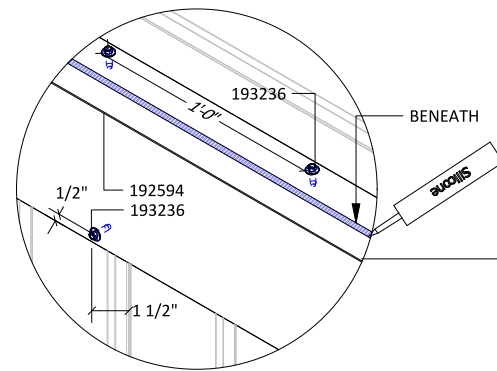
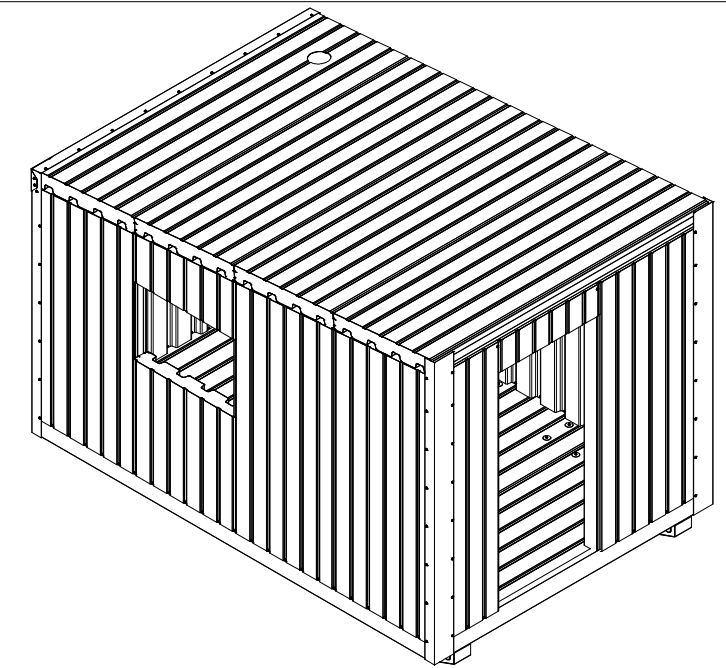

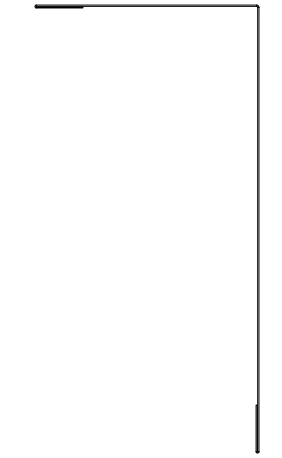

192594(X2)
(ICE SHACK TRIM)

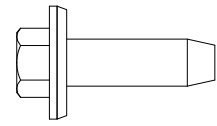

193236(X36)
(#12X1 BLACK SCREW)



192527
(SILICONE)

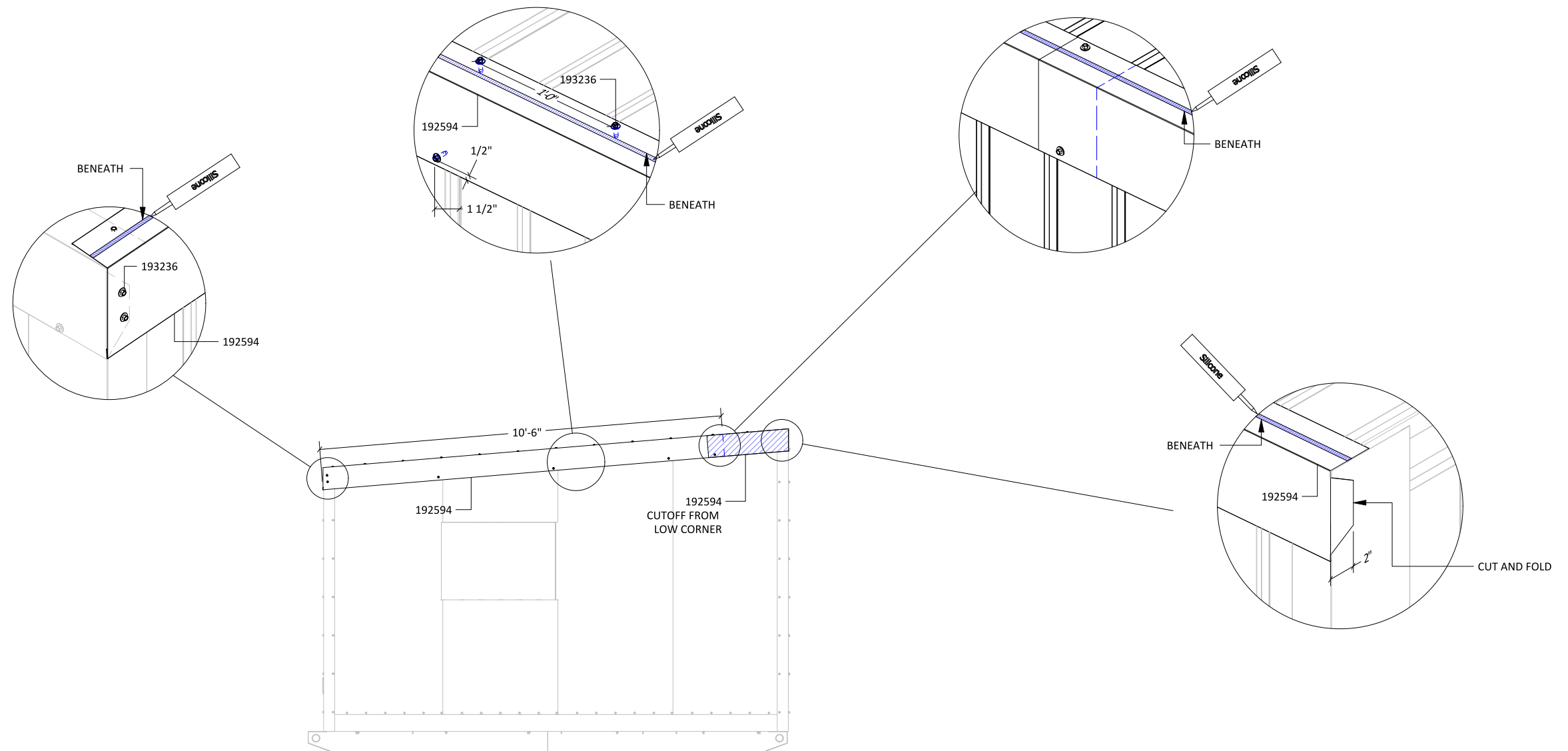
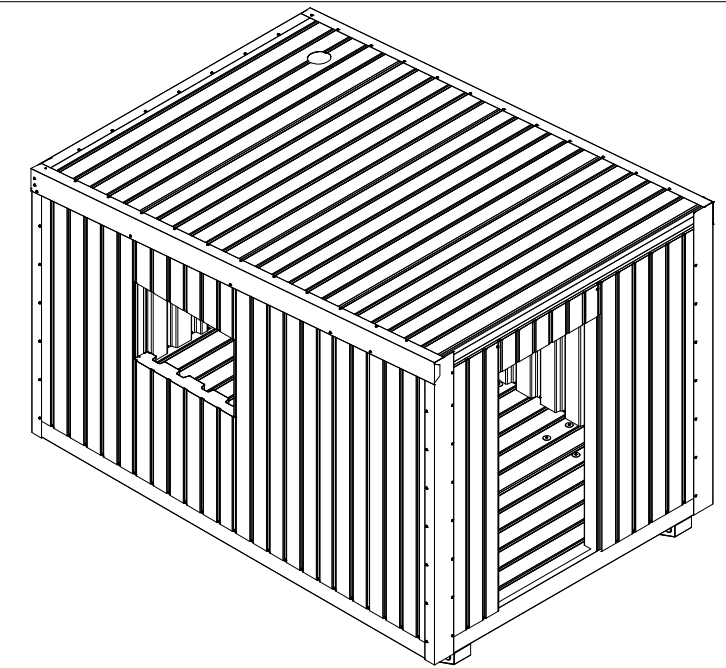

(X2)



192594(X1)
(ICE SHACK TRIM)

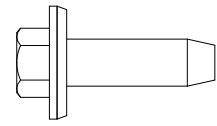

193236(X17)
(#12X1 BLACK SCREW)



192527
(SILICONE)

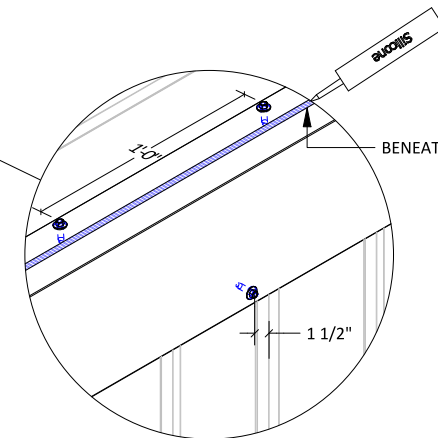
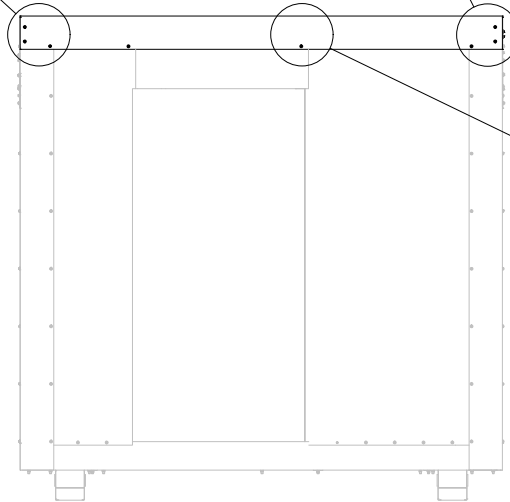
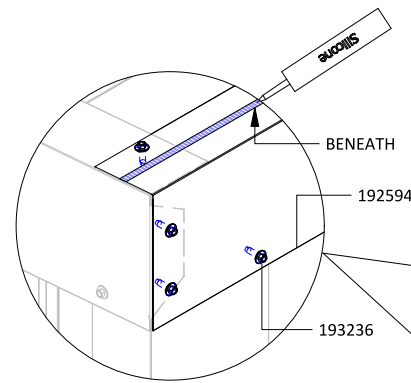
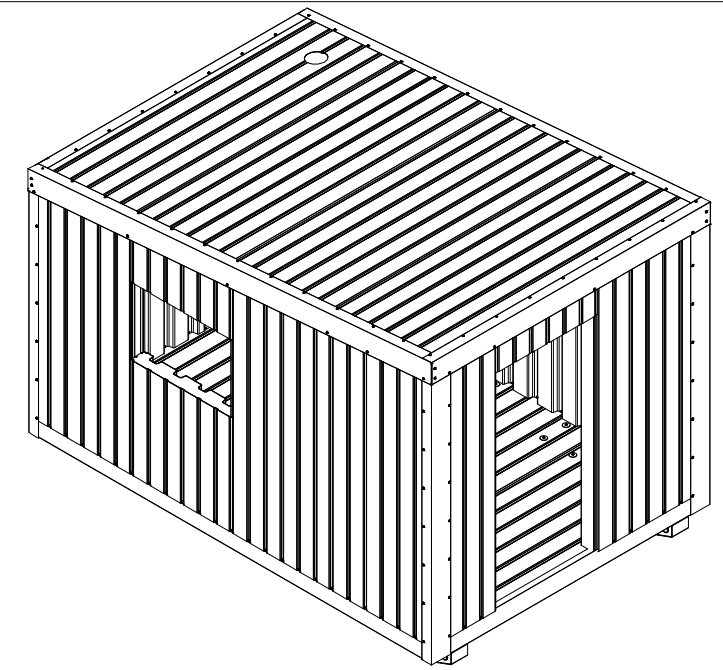

WINDOW & DOOR INSTALLATION PREPARATION:

BEFORE INSTALLING THE WINDOWS OR DOOR, THE PANEL ADJACENT TO THE ROUGH OPENING WILL NEED TO BE PREPARED. SNIP THE TOP(AND BOTTOM FOR WINDOWS) OF THE 3/4" FLANGES THAT PROTRUDES INTO THE WINDOW AND DOOR ROUGH OPENING. AS SHOWN BELOW. ONCE THE CUTS HAVE BEEN MADE BEND THE INSIDE AND OUTSIDE FLANGES INTO THE ROUGH OPENING AS SHOWN IN DETAIL A BELOW.

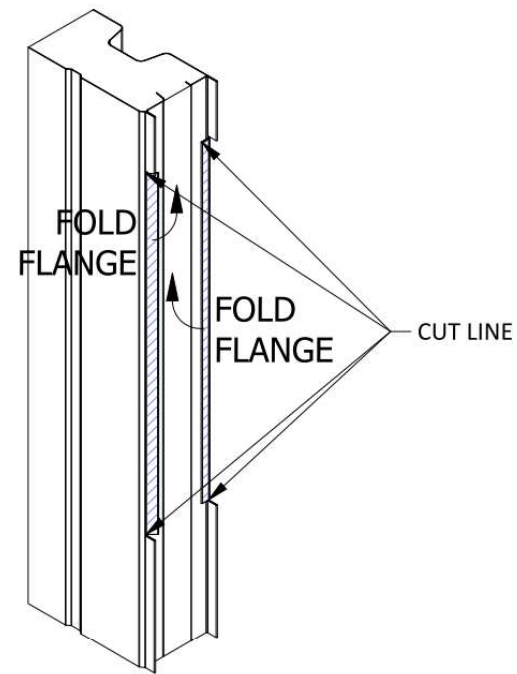
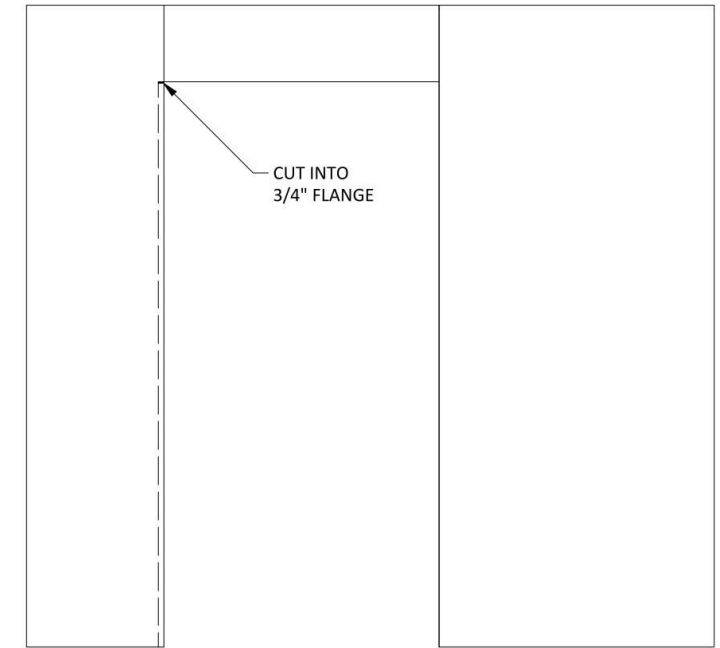
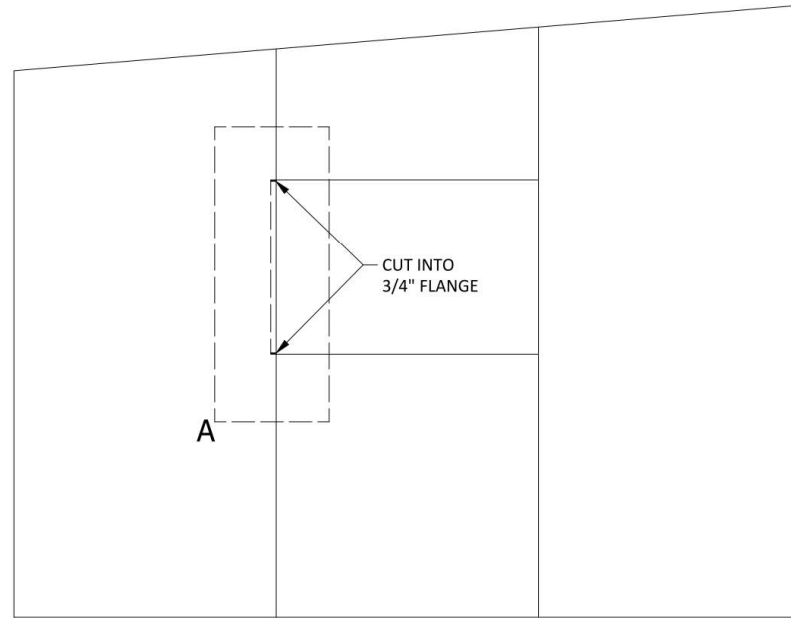
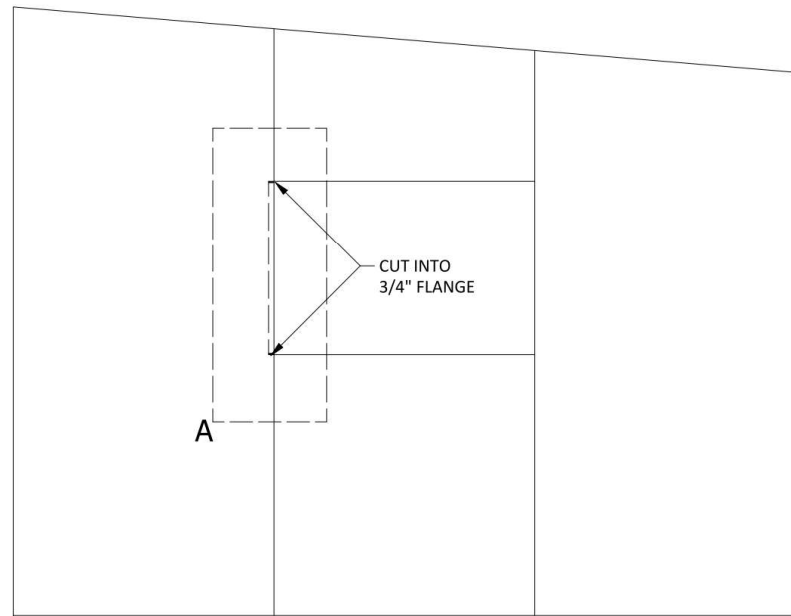

SNIP DETAIL A

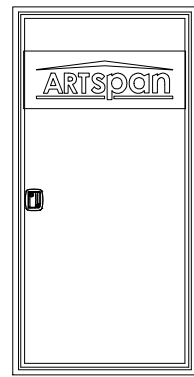

192716(X1)
(36" DOOR)

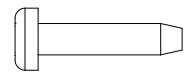

193218(X36)
(#8X3/4" POINTED SCREW)



192522
(SIKAFLEX 1A)



192593(X2)
(INSIDE DOOR TRIM)

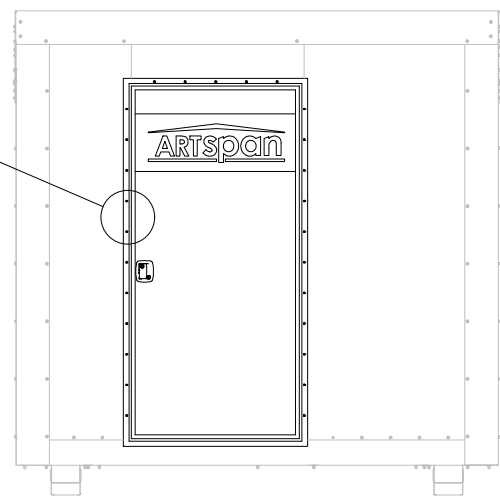
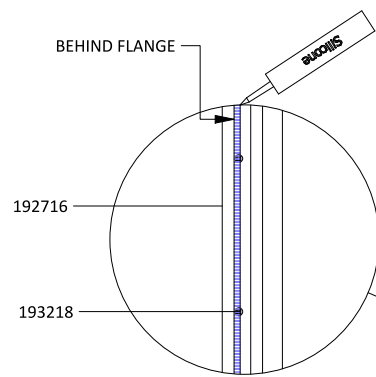
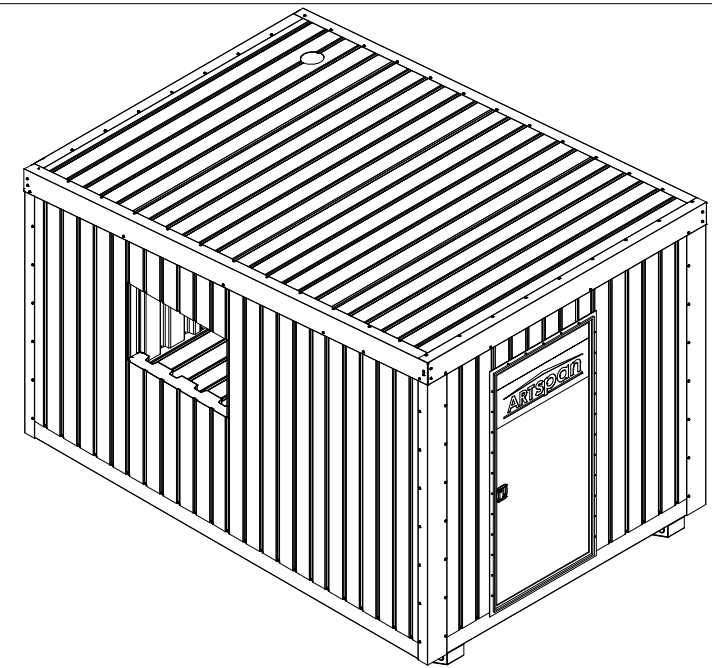

(OUTSIDE VIEW)

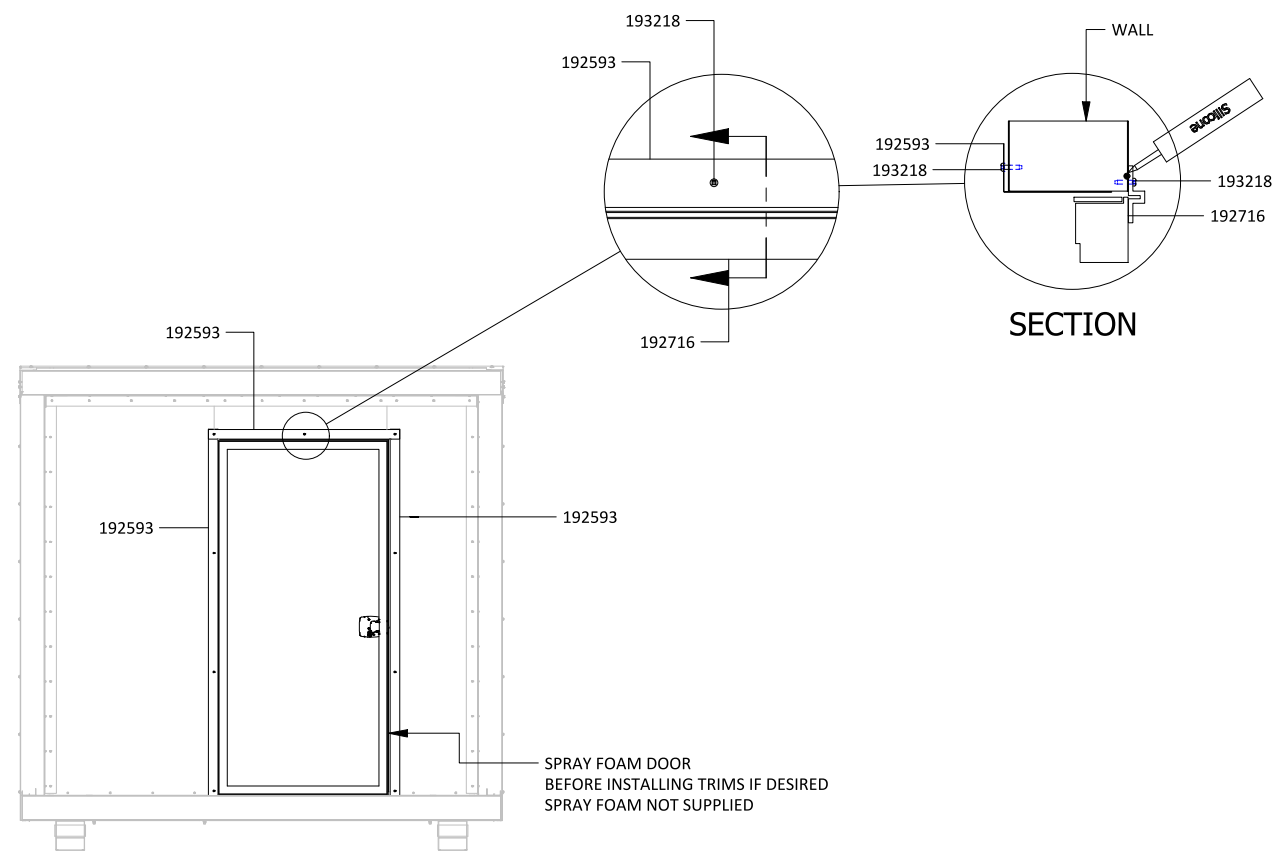

(INSIDE TRIM VIEW)

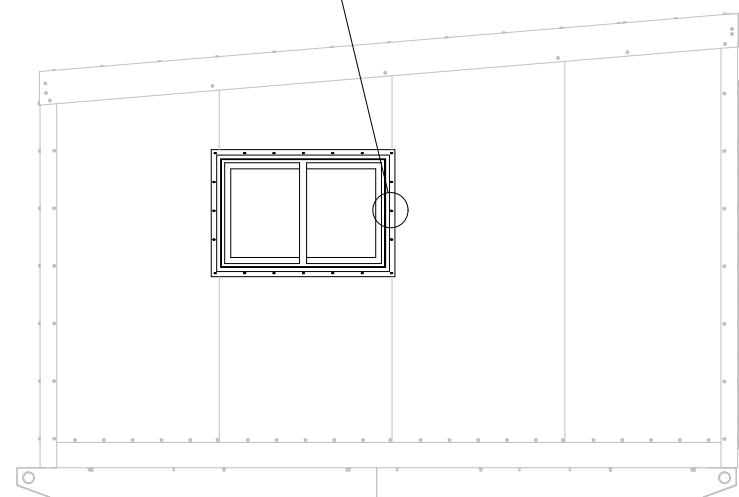
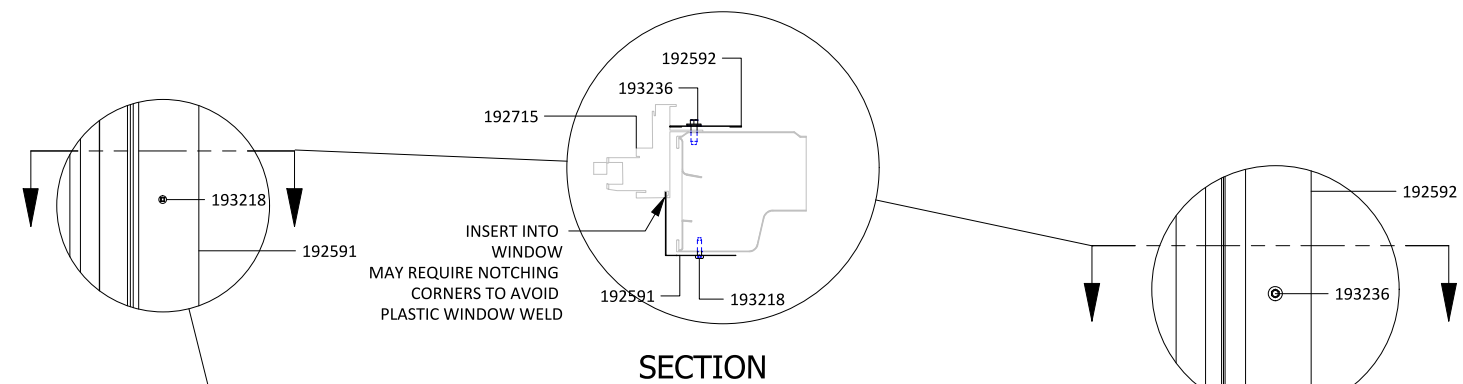
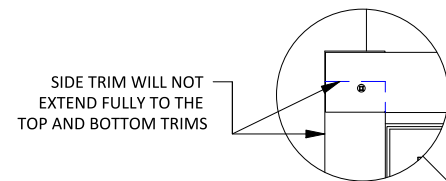
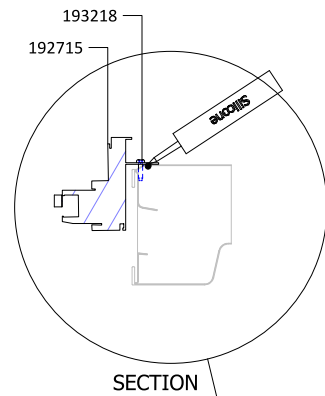
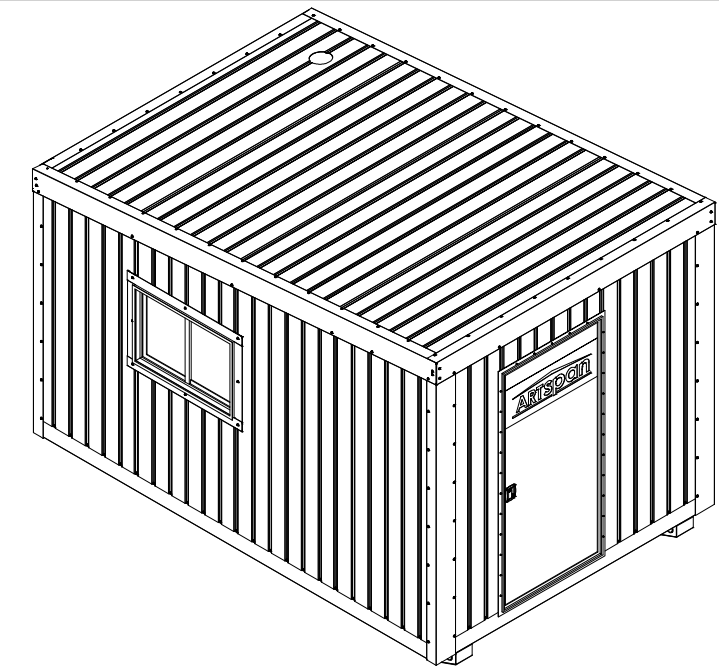
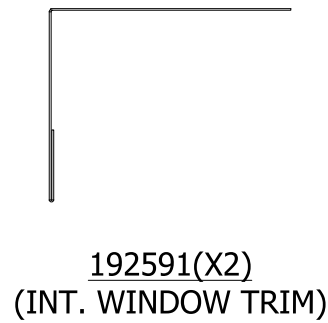
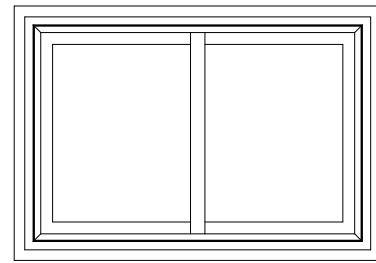
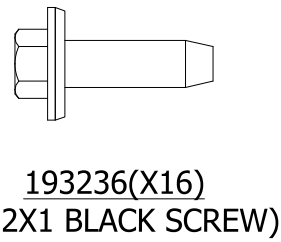
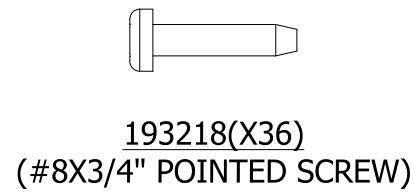
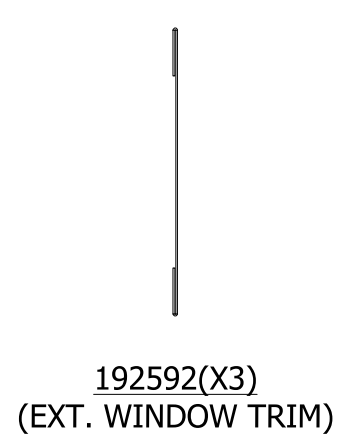

OUTSIDE WINDOW INSTALL VIEW(X2)

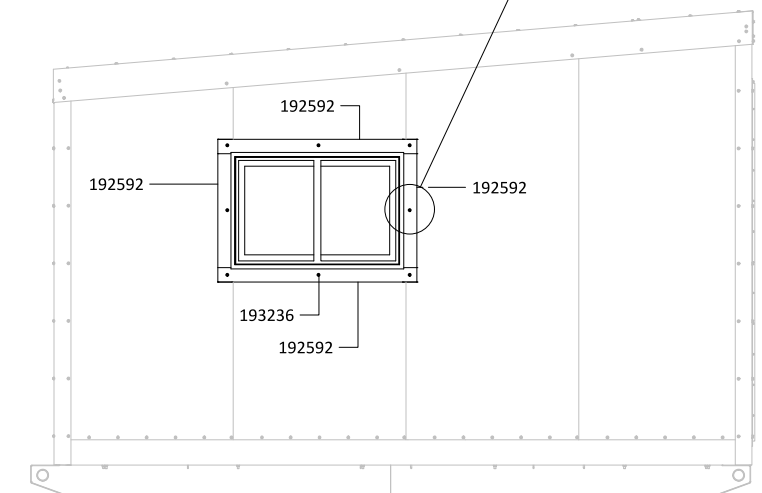
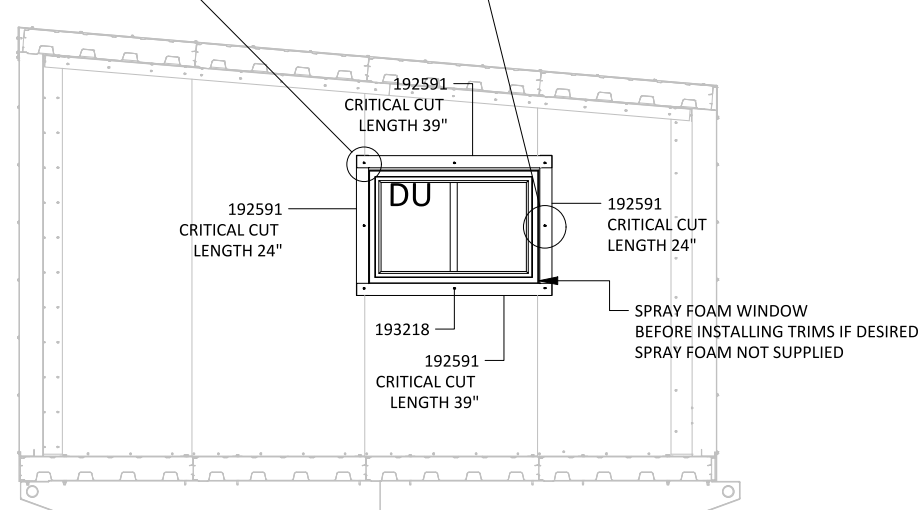

OUTSIDE TRIM VIEW(X2)

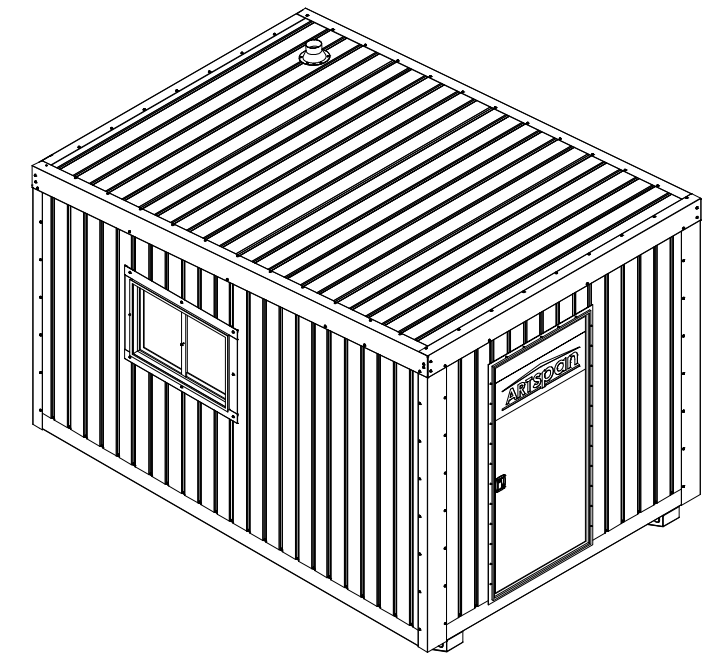
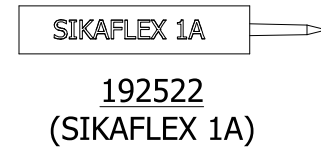
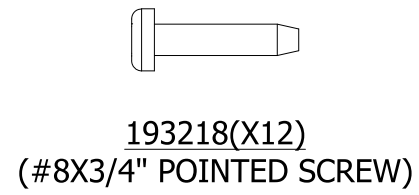
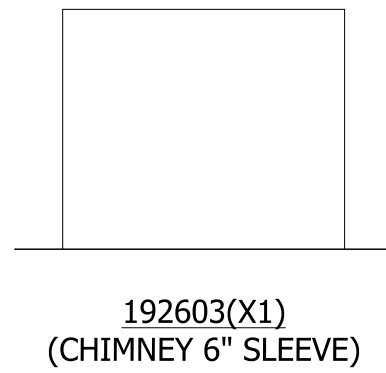
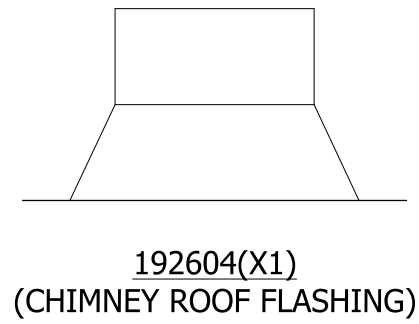

WARNING:
CONSULT RECOMMENDED VENTILATION GUIDELINES FROM
HEAT APPLIANCE MANUFACTURER PRIOR TO USE TO
ENSURE ICE SHACK IS PROPERLY VENTILATED.

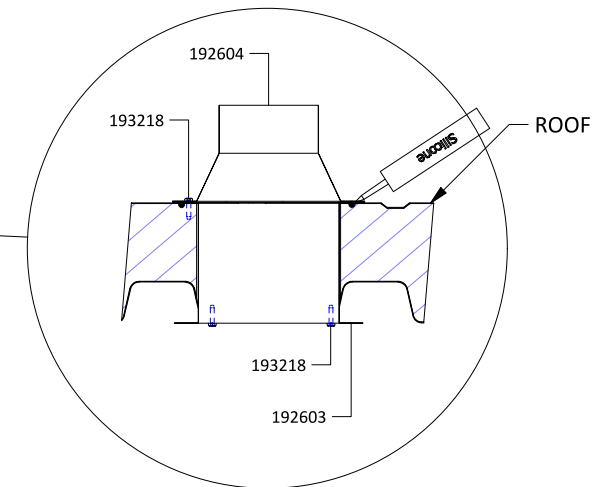
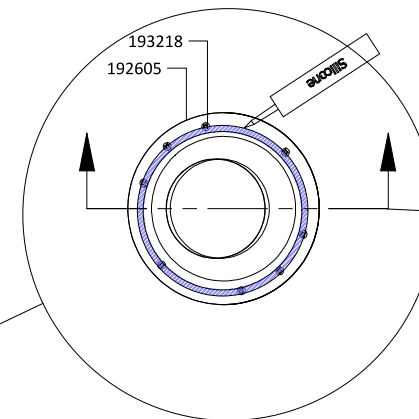

SECTION

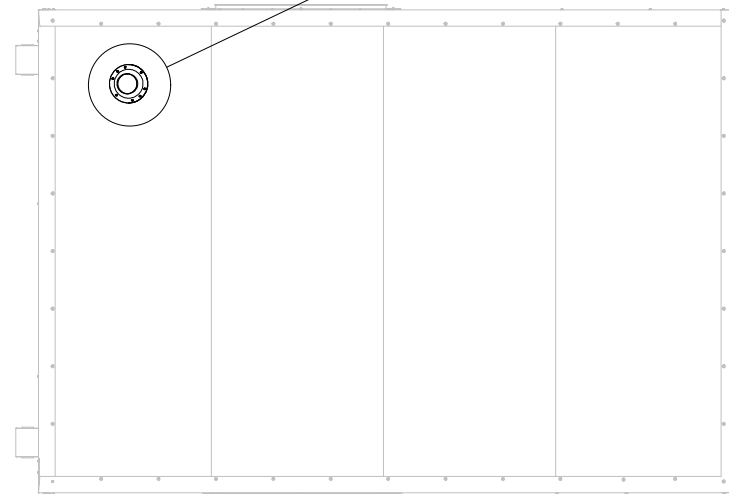

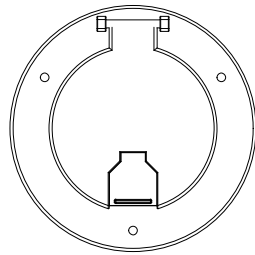

192569(X2)
(BLACK 3 1/2" INLET PORT)

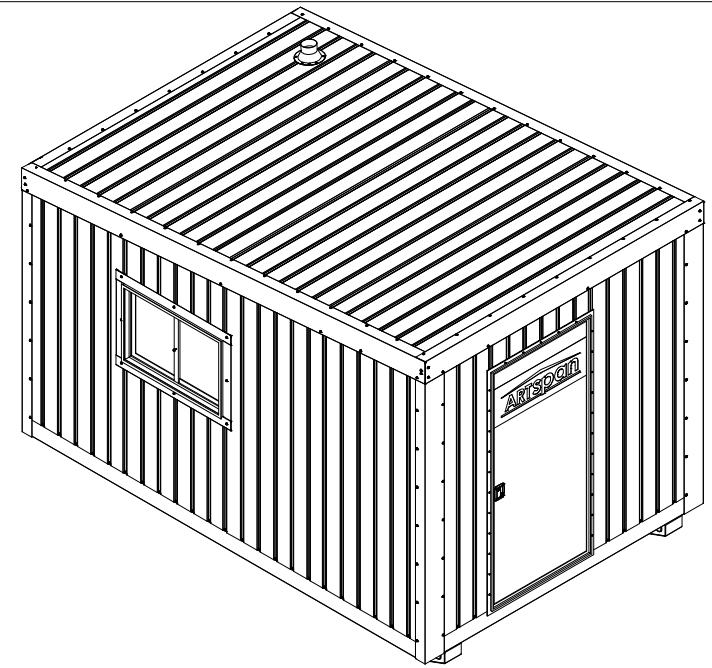

WARNING:
CONSULT RECOMMENDED VENTILATION GUIDELINES FROM
HEAT APPLIANCE MANUFACTURER PRIOR TO USE TO
ENSURE ICE SHACK IS PROPERLY VENTILATED.

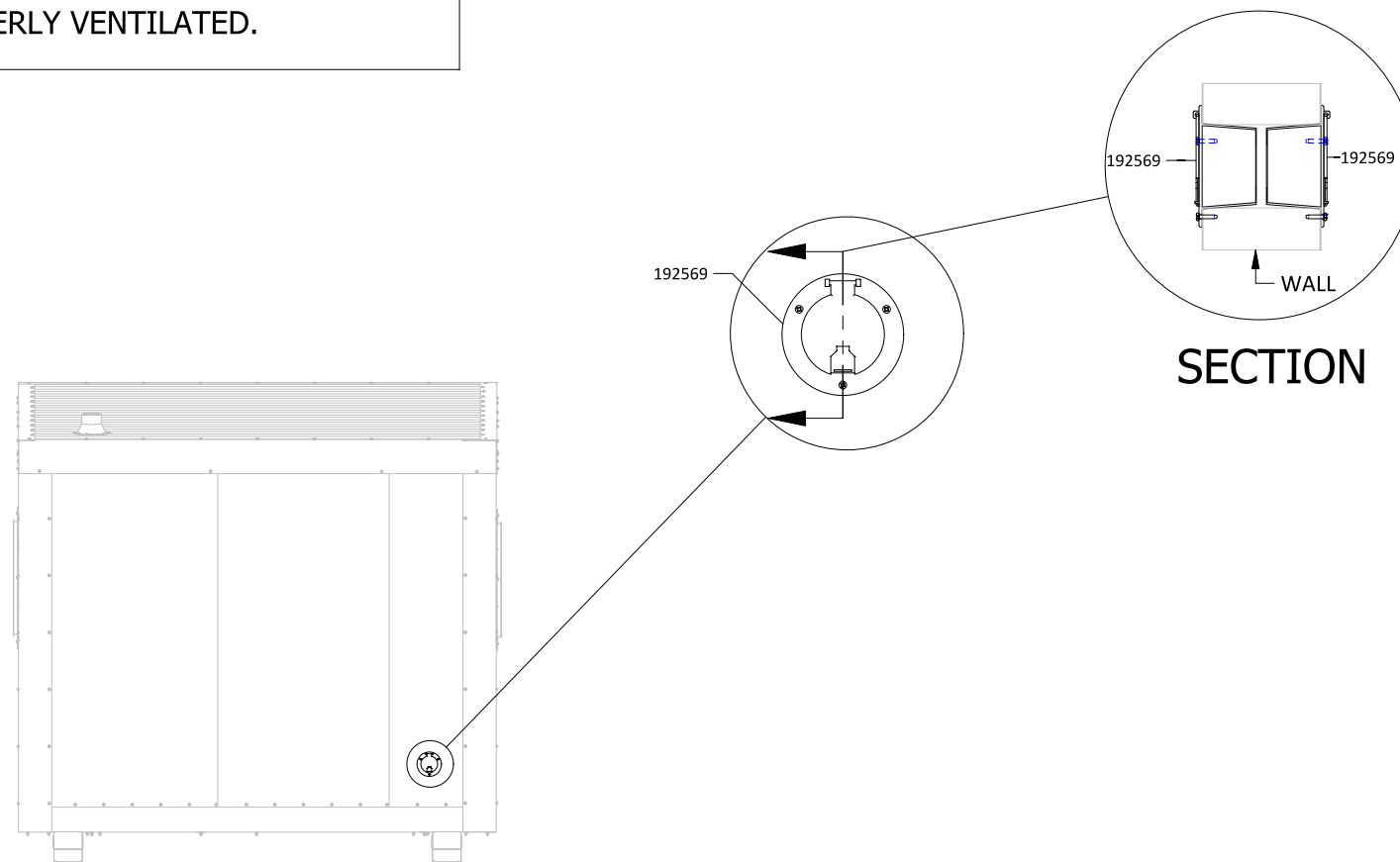

193224(X3)
(3/8" X 3 1/2" BOLT)

193227(X3)
(3/8" LOCK NUT)



192621(X6)
(2" TUBE PLUG)

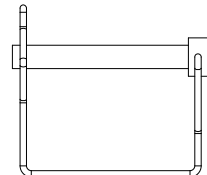

193223(X1)
(3/8" LYNCH PIN)

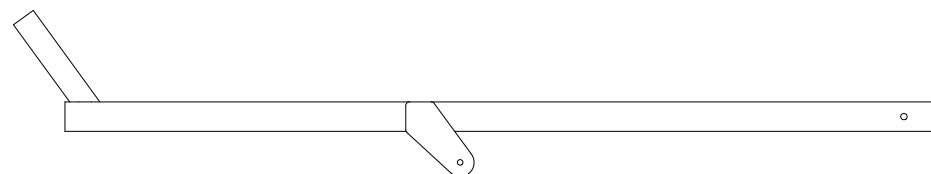

192618(X2)
(TOW BAR ARM)

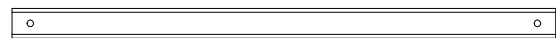

192619(X1)
(TOW BAR CROSS TUBE)

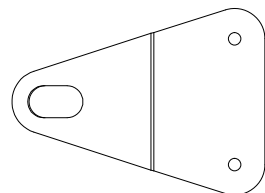

192620(X2)
(TOW BAR PLATE)

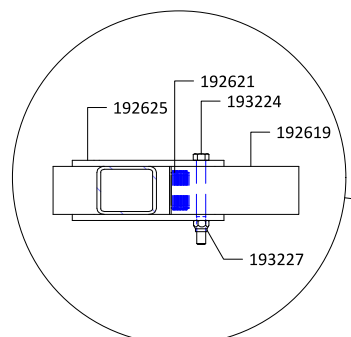
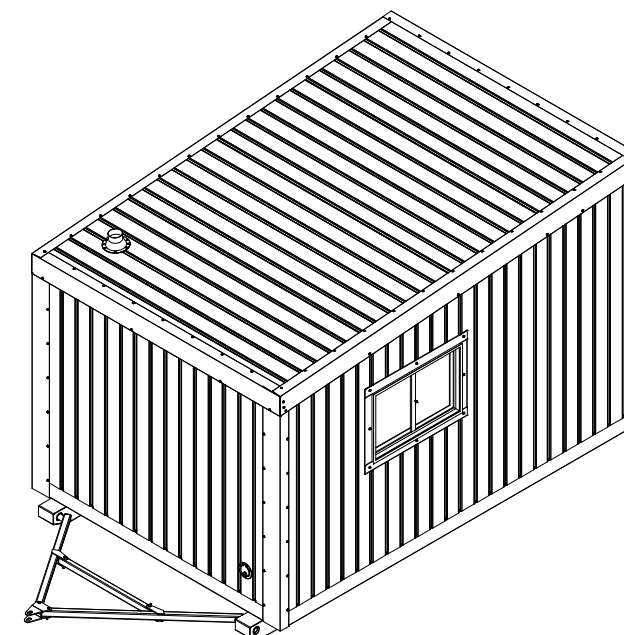

SECTION

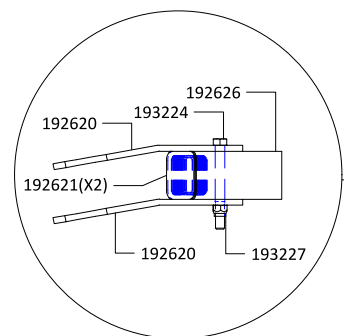
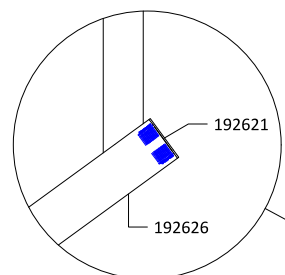
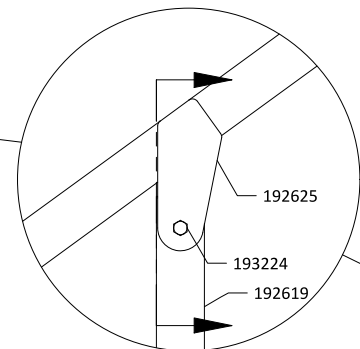

SECTION

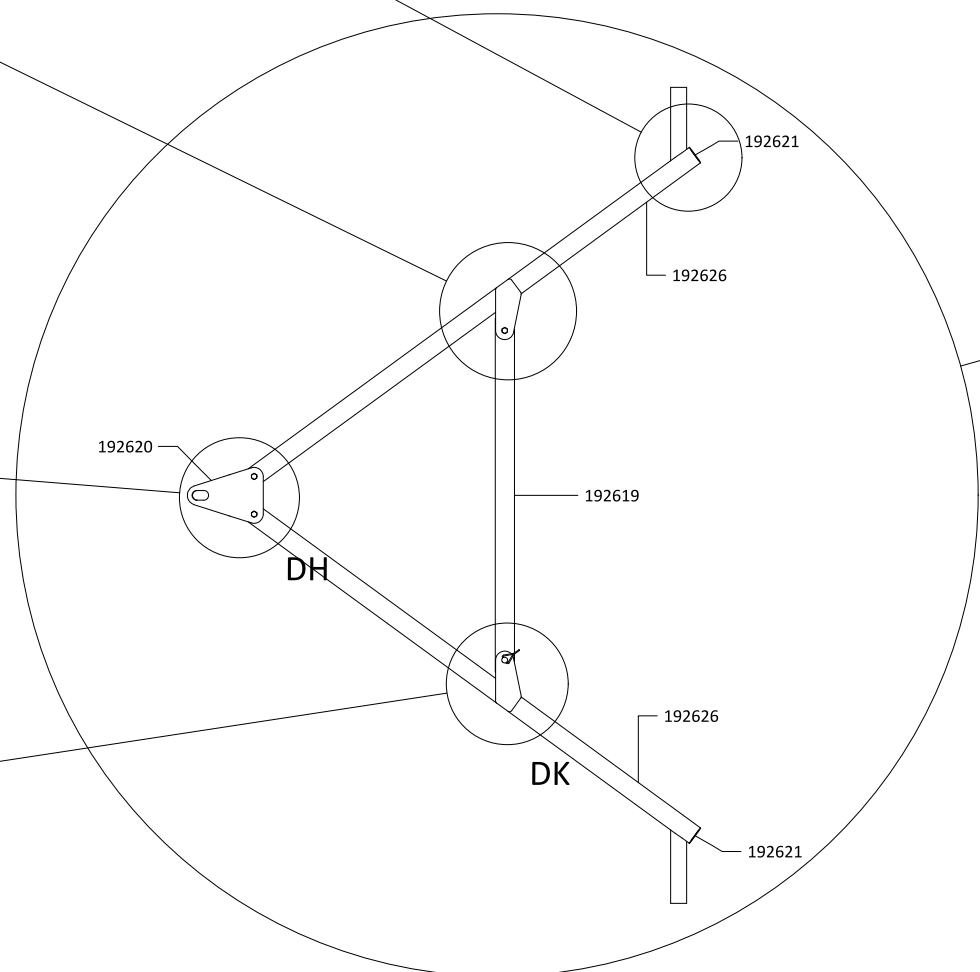
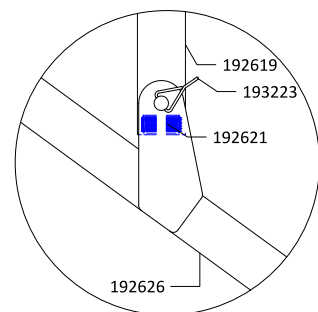
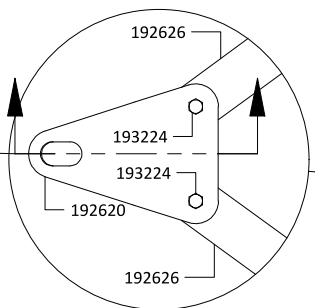

WARNING:

- DO NOT EXCEED SPEEDS OF 10 KM/HR WHILE TOWING ICE SHACK
- ENSURE SKIES ARE BROKEN FREE FROM ICE/SNOW PRIOR TO TOWING

